

Birla Precision

Machining Center Tooling

ISO 9001 : 2000
ISO 14001 : 2004
CERTIFIED



BPT
BIRLA
PRECISION



THE YASH BIRLA GROUP

BIRLA PRECISION

AT3 CLASS PRECISION ROTATING TOOL HOLDERS

AT3

WHAT DOES AT3 CLASS MEAN ?

According to the ISO standards, there are 7 Angular Tolerance (AT) grades, as given under.

ATD - Values in mm and **AT α** Angular Values in Seconds (").

TOLERANCE ZONES

Taper		Gauges				Hi-Speed/Hi Accuracy Machining				Normal Machining		Utility Application			
		Master		Working		AT 2		AT 3		AT 4		AT 5		AT 6	
		AT 0	AT 1	AT 2	AT 3	AT 4	AT 5	AT 6							
Size	Length	ATD	AT α	ATD	AT α	ATD	AT α	ATD	AT α	ATD	AT α	ATD	AT α	ATD	AT α
30	47,63	0,0006	0"	0,0010	4"	0,0015	6"	0,0023	10"	0,0038	16"	0,0061	26"	0,0095	41"
40	68,25	0,00069	0"	0,0011	3"	0,0017	5"	0,0028	8"	0,0043	13"	0,0069	21"	0,0109	33"
50	101,60	0,0011	0"	0,0017	2,5"	0,0020	4"	0,0033	6"	0,0051	10"	0,0081	16"	0,0127	26"

WHY BIRLA PRECISION TOOL HOLDERS?

Birla Precision AT3 Class tool holders represent the highest degree of technical excellence and are the perfect answer to the needs of high speed and high accuracy machining. These international quality tool holders are characterized by controlled case depth and a black oxide surface.



TURNING + MILL SECTION ▲



▲ GRINDING SECTION (24 HRS. AC)



▲ TAPER GRINDING ON STUDER MACHINE

EXCELLENT AND CONTROLLED OPERATING CONDITIONS

AT3 accuracy is made possible by not only state-of-the-art machines like a CNC Studer Grinder and highly sophisticated and sensitive precision measuring equipments such as Stoz air electronic gauging system, Scan max-CMM, CAD/CAMS etc. but by creating a fully air conditioned working environment for 24 hours throughout 365 days in grinding section to control dimensional accuracies as well as repeatability.

The processes are controlled through implementation of International Quality Management Systems (ISO 9001: 2000 and ISO 14001: 2004), through SPC, RFT Indexes and Run charts.

TURN-MILL CENTRE



WHY THE BLACK OXIDE FINISH?

The black oxide surface finish protects ungrounded surfaces from atmospheric reactions during use; it also results in greater visual appeal.

WHY CONTROLLED CASE DEPTH?

Controlled case depth gives AT3 class tool holders advantages like:

- Freedom from cracks, created by the brittleness that results from higher case depth.
 - High impact resistance, not provided by lower case depth.
- Birla Precision achieves controlled case depth by virtue of oxygen probe controlled carburizing.

ACCURATE, OBJECTIVE MEASUREMENTS

The Electronic Air Gauging System used by Birla Precision to measure the accuracy of AT3 Class tool holders is state-of-the-art, sensitive and very precise than the Blue Bearing or Air column Inspection methods as both these are subjective, time consuming, inconsistent and inaccurate.



▲ AT3 TAPER CHECK ON AIR ELECTRONIC GAUGE



CNC INTERNAL GRINDING ▶

WHY YOU NEED AT3 CLASS ACCURACY?

AT3 Class accuracy results in various advantages during machining such as:

- Greater contact area with machine spindle, resulting in longer spindle bearing life.
- Less vibration and chatter during milling.
- Longer cutting tool life.
- Improved run out accuracy and surface finish.
- Higher metal removal rate.
- Enhanced safety.

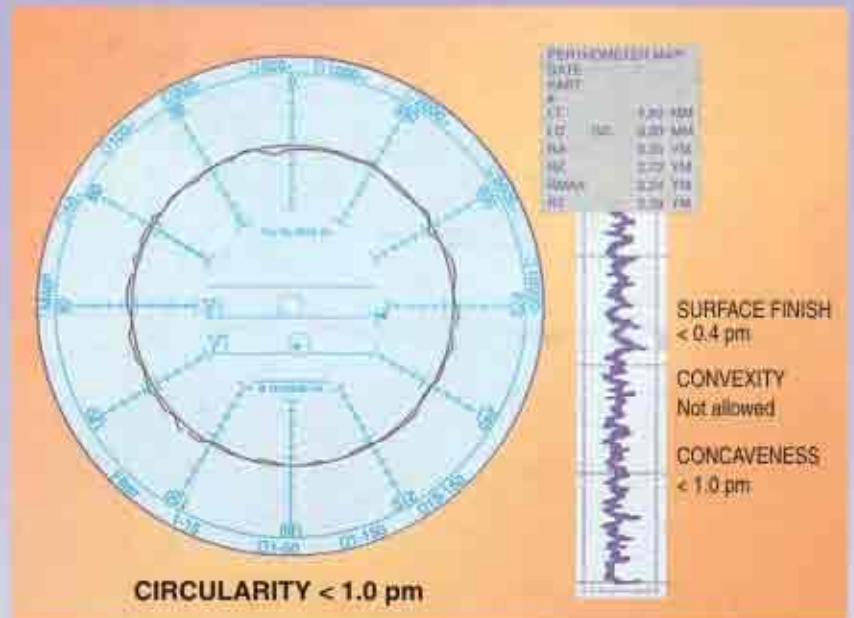

▶ AT3 TOOL HOLDER ACCURACY



▶ BALANCING MACHINE

TABLE OF CONTENTS

Product Code Identification System	1
Tool Holder Selection Guide (Page references)	2-3
BT Taper	
BT-30	4-6
BT-40	7-11
BT-50	12-15
CV Taper	
CV-40	16-22
CV-50	23-29
HSK Taper	
HSK-63A	30-34
Straight Shank	35
R8 Shank	36
Collets	
ER-Collet	37-39
TG-Collet	40-42
DA-Collet	43
Hydraulic Sleeve	44
R8-Collet	45
Tightening Fixtures	45
Pull Studs	46
Technical Data	47-55

Product Code



Product Code Identification System

Steep Taper Shank

1. Attachment BT - MAS 403, JIS B 6339 CV - ANSI B5 50/ISO 7388	3. Form B - Coolant through the flange	5. Types Size/Series Examples: TG = Collet Series XX(50), XXX(100) EM = ID Size, Metric - XX=XX,(20) Inch - XXX = X.XX (075) SM = OD Size Metric - XX = XX(20), Inch - XXX=X.XX(075)	7. Metric Standard M = Tool built to Metric Values (blank) = Tool built to Inch Values
--	--	---	---

CV	40	B	TG	100	080	M
2. Shank Size Taper size: 30 40 50		4. Toolholder Type ER - ER-Collet Chuck-DIN-6499 SER - ER-Collet Chuck-DIN-6499-Short TG - TG-Collet Chuck DA - DA-Collet Chuck EM - End Mill Adapter DC - Drill Chuck MT - Morse Taper Adapter HC - Hydraulic Chuck SF - Shrink Fit Adapter SM - Shell Mill Adapter JT - Jacobs Taper Adapter SA - Slitting Cutter Adapter BB - Boring Bar Blank		6. Projection Length from the Gauge Line Tool Length		

HSK Shank

1. Attachment HSK-Shank Style	3. Form 3.Form DIN Form A = Form A B = Form B C = Form C D = Form D E = Form E F = Form F	5. Types Size/Series Examples: TG = Collet Series XX(50), XXX(100) EM = ID Size, Metric - XX=XX,(20) Inch - XXX = X.XX (075) SM = OD Size Metric - XX = XX(20), Inch - XXX=X.XX(075)	7. Metric Standard M = Tool built to Metric Values (blank) = Tool built to Inch Values
---	--	---	---

HSK	63	A	TG	100	080	M
2. Shank Size Taper size: 63		4. Toolholder Type ER - ER-Collet Chuck-DIN-6499 TG - TG-Collet Chuck EM - End Mill Adapter DC - Drill Chuck MT - Morse Taper Adapter SF - Shrink Fit Adapter SM - Shell Mill Adapter SA - Slitting Cutter Adapter BB - Boring Bar Blank		6. Projection Length from the Gauge Line Tool Length		

Collet







1. Collet Series	2. Collet Type DA - Double Angle TG - Tremendous Grip ER - DIN 6499 HC - Hydraulic Sleeve	3. Collet Ø Ø 8 = 080 Ø 10 = 100 Ø 12.5 = 125	4. Metric Standard M = Metric Blank - Inch Value
100	TG	060	M
DA TG ER HC R8 000 75 16 1/2" 300 100 25 3/4" 200 150 32 1 1/4" 100 40 180			

Toolholder Selection Guide (Page References)

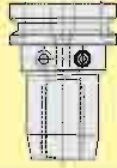

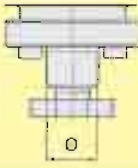
Machining Center Corner FIG.		ER Collet Chucks	TG Collet Chucks	DA Collet Chucks	End Mill	Drill Chucks	Morse Taper
Steep Taper V-Flange							
	BT 30	4	4	-	5	-	-
	BT 40	7	8	8	9	9	10
	BT 50	12	12	-	13	13	14
	CV 40	16	17	17	18	19	19
	CV 50	23	24	24	25	26	26
HSK - Taper Face Toolholders							
	HSK 63A	30	30	-	31	31	32
Straight Shank Extensions							
	ER & DA on SS	35	-	35	-	-	-
	EM & SM on R8	-	-	-	36	-	-
Collets							
	ER	37-39	-	-	-	-	-
	TG	-	40-42	-	-	-	-
	DA	-	-	43	-	-	-
	R8	-	-	-	-	-	-
Sleeves							
	HC Sleeves	-	-	-	-	-	-
	Tightening Fixtures	-	-	-	-	-	-

Toolholder Selection Guide (Page References)

Hydraulic Chucks	Shrink Fit	Shell Mill Adapter	Jacob/ Adapter	Boring Bar Blanks	Pull Studs/ Retention Knobs & Accessories	TECHNICAL INFORMATION
						
5	-	6	-	-	46	47
10	-	11	11	-	46	47
14	-	15	-	-	46	47
20	21	22	22	20	46	48
27	28	29	29	27	46	48
-	33	34	-	32	-	49
-	-	-	-	-	-	-
-	-	36	-	-	-	-
-	-	-	-	-	-	55
-	-	-	-	-	-	55
-	-	-	-	-	-	55
-	-	-	-	-	45	-
44	-	-	-	-	-	-
-	-	-	-	-	45	-

BT30 Shank Tools

MAS 403, JIS B 6339



ER Collet Chucks

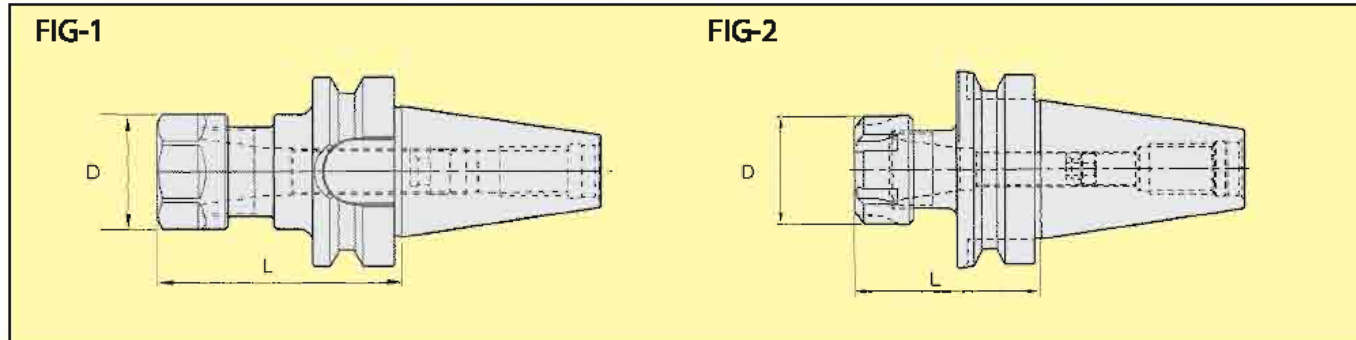

- Balanced by Design, Through tool holder coolant capability
- Order Example – BT30ER16060M
- Dynamically balanced to G6.3 @ 15,000 rpm, & G2.5 at 20,000 rpm available on request
- Order Example – BT30ER16060M-G2.5

Catalogue No.	Collet Series	Collet Cap Min.-Max.	Fig	D	L	Wt. Kg.	Locknut	Wrench	Stop Screw
BT30ER16060M	16ER	0.5 - 10	1	28	60	0.6	LNHER16M	OEW25M	BSS044038G
BT30ER20060M	20ER	0.5 - 13	1	34	60	0.6	LNHER20M	OEW30M	BSS056041G
BT30ER25060M	25ER	1 - 16	2	42	60	0.6	LNER25M	ER25WM	BSS075041G
BT30ER32070M	32ER	2 - 20	2	50	70	0.6	LNER32M	ER32WM	BSS094041G

TG Collet Chucks

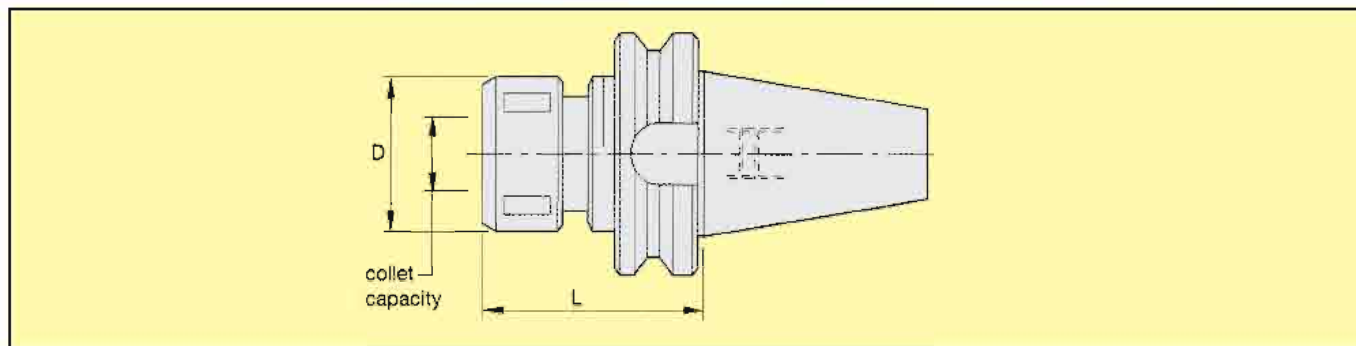

- Tremendous Grip, Balanced by Design, Through tool holder coolant capability
- Order Example – BT30TG07575M
- Dynamically balanced to G6.3 @ 15,000 rpm, & G2.5 at 20,000 rpm available on request
- Order Example – BT30TG075075M-G2.5

Catalogue No.	Collet Series	Collet Cap Min.-Max.	D	L	Wt. Kg.	Locknut	Wrench	Stop Screw
BT30TG075075M	75TG	2.6 - 20	50	75	0.6	LNA075M	HSW45M	BSS081041G

BT30 Shank Tools

MAS 403, JIS B 6339



End Mill Adapters – Inch

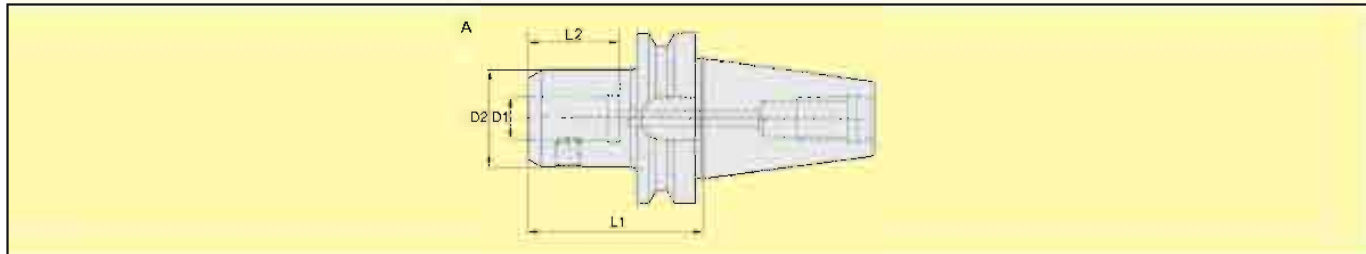

- Balanced by Design, Through tool holder coolant capability
- Order Example – BT30EM012236M
- Dynamically balanced to G6.3 @ 15,000 rpm, & G2.5 at 20,000 rpm available on request
- Order Example – BT30EM012236-G2.5

End Mill Adapters – Inch

Catalogue No.	D1	D2	L1	L2	Wt. Lbs	Clamping Screw	No. of Screw	Allen Key
BT30EM012236	1/8	0.69	2.36	3.30	0.94	BS1045PKG	1	3/32
BT30EM018236	3/16	0.69	2.36	3.30	0.94	BS1045PKG	1	3/32
BT30EM025236	1/4	1.00	2.36	3.30	1.10	BELS025025PKG	1	1/8
BT30EM031236	5/16	1.00	2.36	3.30	1.08	BELS031031PKG	1	5/32
BT30EM038236	3/8	1.00	2.36	3.30	1.08	BELS038031PKG	1	3/16
BT30EM050236	1/2	1.38	2.36	1.97	1.26	BELS044038PKG	1	7/32
BT30EM062236	5/8	1.63	2.36	2.09	1.42	BELS056050PKG	1	1/4
BT30EM075236	3/4	1.75	2.36	2.22	1.45	BELS062050PKG	1	5/16

Hydraulic Chucks - Inch

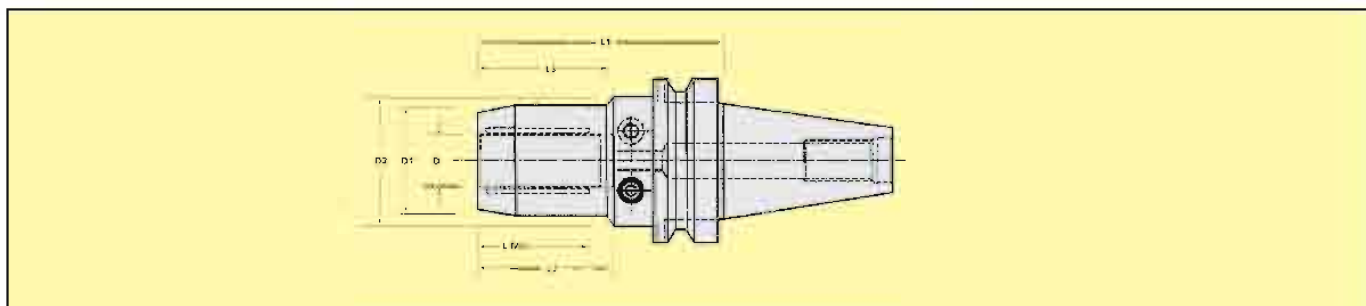

- Pre Balanced G6.3 @ 15,000 rpm
- Through tool holder coolant capability
- Order Example – BT30-SHYD050-335
- Dynamically balanced to G6.3 at 15,000 rpm, & G2.5 at 20,000 rpm available on request
- Order Example – BT30-SHYD050-335-G2.5

Hydraulic Chucks – Inch

Catalogue No.	D	D1	D2	L1	L2	L3	L Min.	Pressure Screw	Stop Screw	Wt. Lbs
BT30-SHYD050-335	1/2"	32	50	3.35"	45	40	36	SHYDC-0717	CSS-0615M	1.50
BT30-SHYD075-413	3/4"	42	50	4.13"	52	50	43	SHYDC-0717	CSS-0815M	2.65

BT30 Shank Tools

MAS 403, JIS B 6339



Shell Mill Adapters – Inch

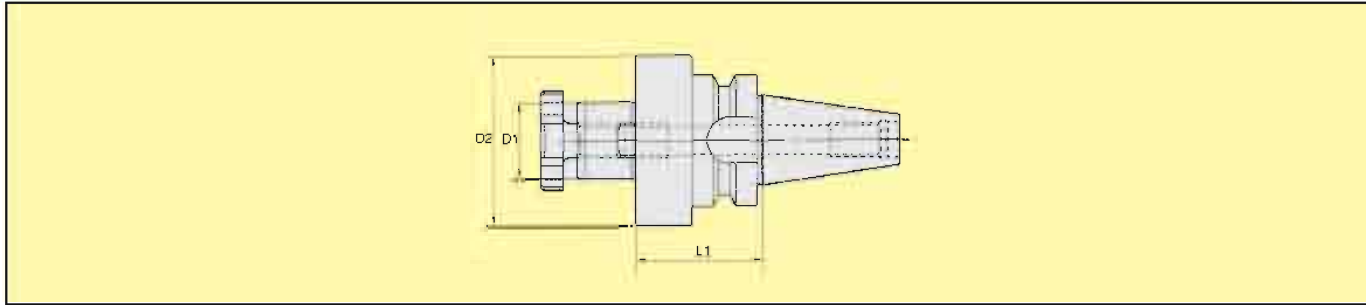

- Balanced by Design
- Through tool holder coolant capability
- Order Example – BT30SM050118

Shell Mill Adapters – Inch

Catalogue No.	D1	D2	L	Wt. Lbs	Lock Screw	Wrench	Drive Key
BT30SM050118	½	1.44	1.18	2.10	BKLS05	3/16	BKDK04
BT30SM075118	¾	1.69	1.18	2.30	BKLS07	1/4	BKDK05
BT30SM100177	1.00	2.19	1.77	2.48	BKLS10	5/16	BKDK06

BT40 Shank Tools

MAS 403, JIS B 6339



ER Collet Chucks

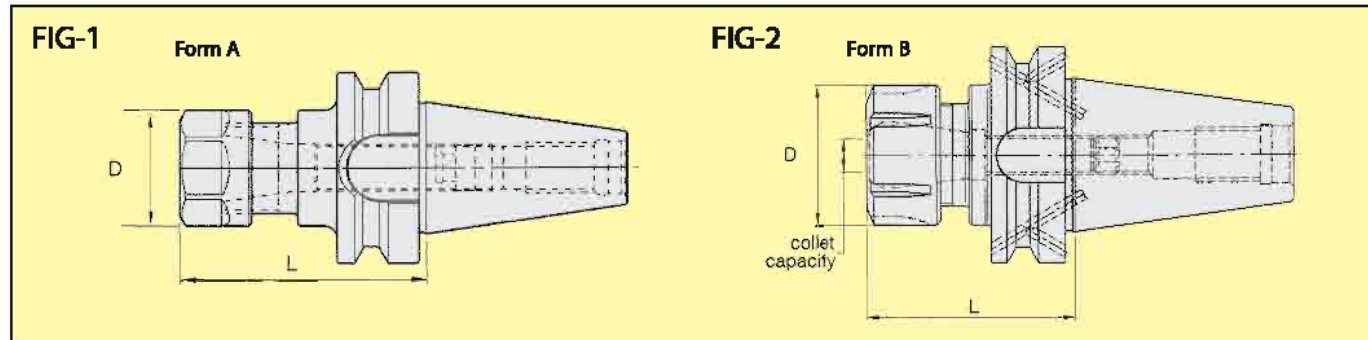

- Balanced by Design
- Through tool holder coolant capability
- Order Example – BT40ER16060M
- Dynamically balanced to G6.3 @ 15,000 rpm, G2.5 at 20,000 rpm available on request
- Order Example – BT40ER16060M-G2.5

Flange through coolant Form B/AD available on request
Order Example – BT40BER16060M

Catalogue No.	Collet Series	Collet Cap Min.-Max.	Fig	D	L	Wt. Kg.	Locknut	Wrench	Stop Screw
BT40ER16120M	16ER	0.5 - 10	1	28	120	1.6	LNHER16M	OEW25M	BSS044038G
BT40ER25070M	25ER	1 - 16	2	42	70	1.3	LNER25M	ER25WM	BSS075041G
BT40ER25120M	25ER	1 - 16	2	42	120	1.6	LNER25M	ER25WM	BSS075041G
BT40ER32070M	32ER	2 - 20	2	50	70	1.4	LNER32M	ER32WM	BSS094041G
BT40ER32120M	32ER	2 - 20	2	50	120	1.7	LNER32M	ER32WM	BSS094041G
BT40ER40080M	40ER	3 - 26	2	63	80	1.5	LNER40M	ER40WM	BSS112041G
BT40ER40120M	40ER	3 - 26	2	63	120	1.8	LNER40M	ER40WM	BSS112041G

ER short – BT Form AD

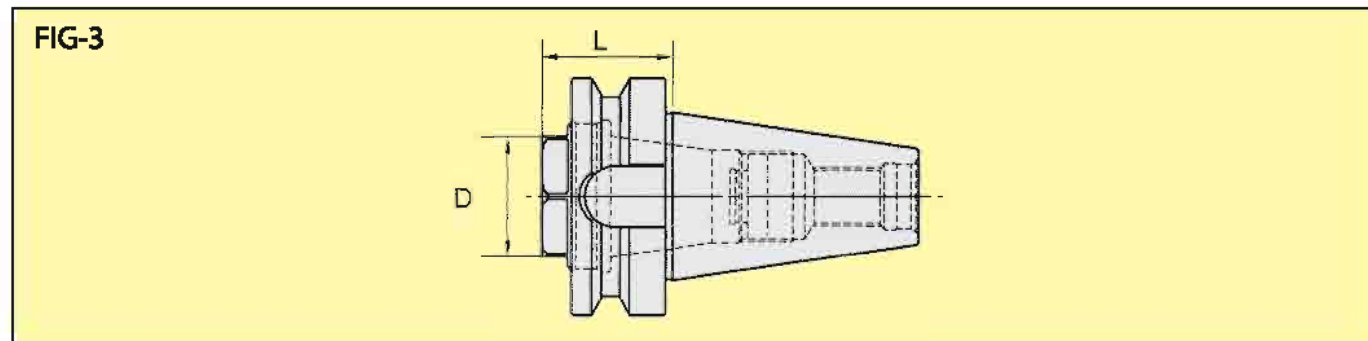

Catalogue No.	Collet Series	Collet Cap Min.-Max.	Fig	D	L	Wt. Kg.	Locknut	Wrench	Stop Screw
BT40SER32035M	32ER	2 - 20	3	36	35	0.75	LNECER32M	OEW32M	SS094041G

BT40 Shank Tools

MAS 403, JIS B 6339



TG Collet Chucks

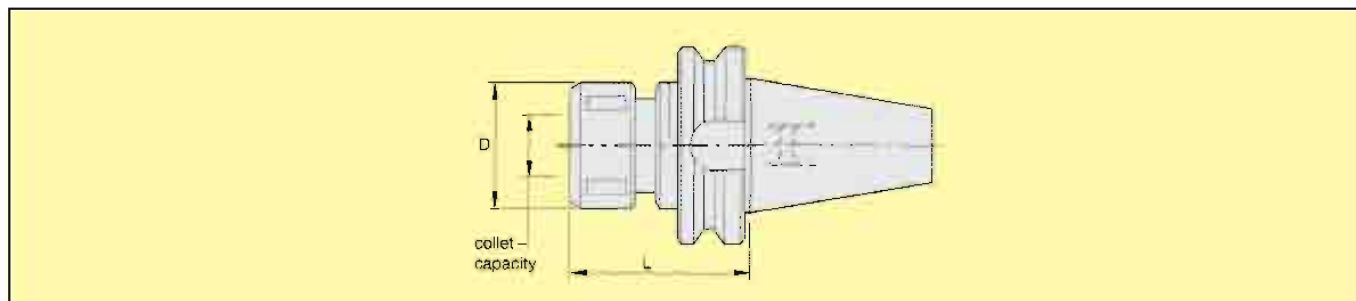

- Tremendous grip, Balanced by Design, Through tool holder coolant capability
- Order Example – BT40TG07570M
- Dynamically balanced to G6.3 @ 15,000 rpm, & G2.5 at 20,000 rpm available on request
- Order Example – BT40TG075070M-G2.5
- Flange through coolant Form B/AD available on request
- Order Example – BT40BTG075070M

Catalogue No.	Collet Series	Collet Cap Min.-Max.	D	L	Wt. Kg.	Locknut	Wrench	Stop Screw
BT40TG075070M	75TG	2.6 - 20	50	70	1.4	LNA075M	HSW45M	BSS081041G
BT40TG100080M	100TG	2.6 - 25.5	60	80	1.4	LNA100M	HSW58M	BSS112041G
BT40TG100100M	100TG	2.6 - 25.5	60	100	1.8	LNA100M	HSW58M	BSS112041G
BT40TG100150M	100TG	2.6 - 25.5	60	150	2.5	LNA100M	HSW58M	BSS112041G

DA Collet Chucks

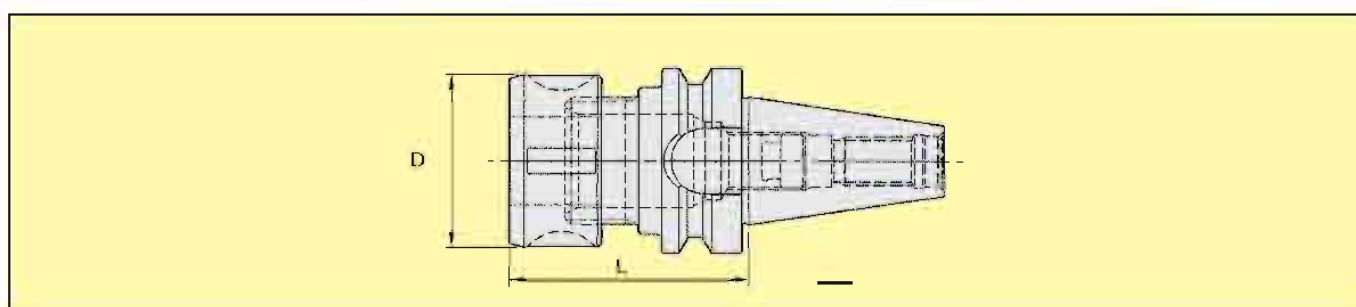

- Balanced by Design, Through tool holder coolant capability. Flange through coolant Form B/AD available on request
- Order Example – BT40DA188070M Order Example – BT40DA188070M
- Dynamically balanced to G6.3 @ 15,000 rpm, & G2.5 at 20,000 rpm available on request
- Order Example – BT40DA188070M-G2.5

Catalogue No.	Collet Series	Collet Cap Min.-Max.	D	L	Wt. Kg.	Locknut	Wrench	Stop Screw
BT40DA188070M	180DA	2.2 - 20	43	70	1.2	LNA188M	HSW45M	BSS081041G
BT40DA188100M	180DA	2.2 - 20	43	100	1.4	LNA188M	HSW45M	BSS081041G

BT40 Shank Tools

MAS 403, JIS B 6339



End Mill Adapters – Inch

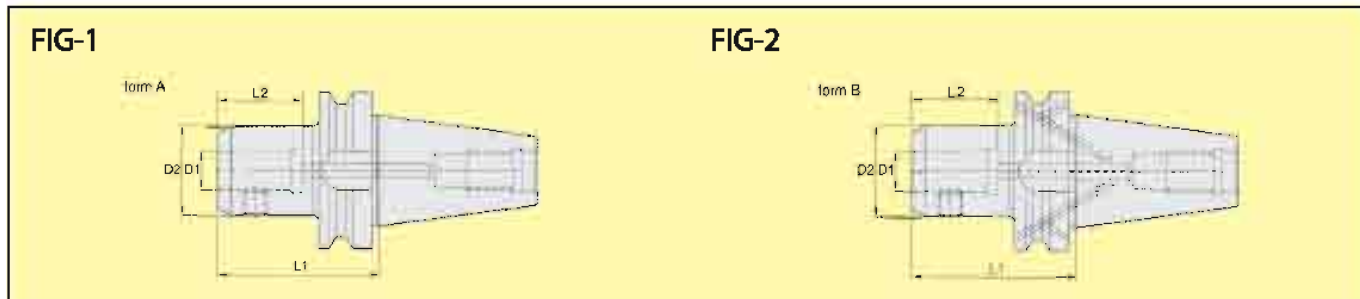

- Balanced by Design, Through tool holder coolant capability
 - Order Example – BT40EM025255
 - Dynamically balanced to G6.3 @ 15,000 rpm & G2.5 at 20,000 rpm, available on request
 - Order Example – BT40EM025255-G2.5
- Flange through coolant Form B/AD available on request
Order Example – BT40EM025255

End Mill Adapters – Inch.

Catalogue No.	FIG	D1	D2	L1	L2	Wt. Lbs	Clamping Screw	No. of Clamp Screw	Wrench Allen Key
BT40EM025255	1	1/4	1.00	2.55	3.93	2.36	BELS025025PKG	1	1/8
BT40EM031255	1	5/16	1.00	2.55	3.93	2.36	BELS031031PKG	1	5/32
BT40EM038255	1	3/8	1.00	2.55	3.93	2.51	BELS038031PKG	1	3/16
BT40EM050255	1	1/2	1.38	2.55	3.93	2.51	BELS044038PKG	1	7/32
BT40EM050400	1	1/2	1.38	4.00	5.38	3.02	BELS044038PKG	1	7/32
BT40EM062255	1	5/8	1.63	2.55	2.09	2.69	BELS056050PKG	1	1/4
BT40EM075150	1	3/4	1.68	1.50	2.22	2.09	BELS062050PKG	1	5/16
BT40EM075255	1	3/4	1.75	2.55	2.22	2.73	BELS062050PKG	1	5/16
BT40EM088335	1	7/8	2.00	3.35	2.22	3.57	BELS062050PKG	1	5/16
BT40EM100162	1	1	2.04	1.63	2.46	2.01	BELS075044PKG	2	3/8
BT40EM100374	1	1	2.00	3.74	2.56	3.75	BELS075056PKG	2	3/8
BT40EM100500	1	1	2.00	5.00	4.49	4.54	BELS075056PKG	2	3/8
BT40EM125335	1	1 1/4	2.40	3.35	2.51	3.95	BELS075056PKG	2	3/8

Drill Chucks

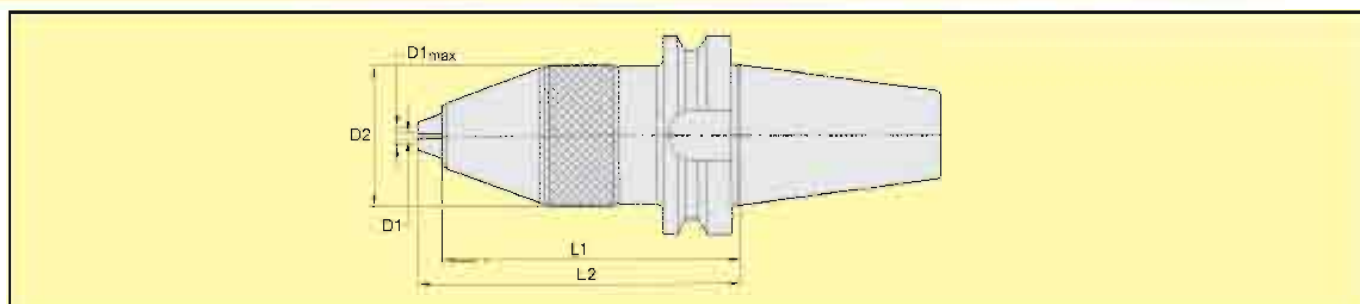

- Balance by design, Through tool holder coolant capability
- Order Example – BT40DC13096M

Catalogue No.	D1 Min.-Max	D2	L1	L2	Wt. Kg	Wrench
BT40DC13096M	1 - 13	50.50	96.40	108.50	1.80	135

BT40 Shank Tools

MAS 403, JIS B 6339



Morse Taper Adapters

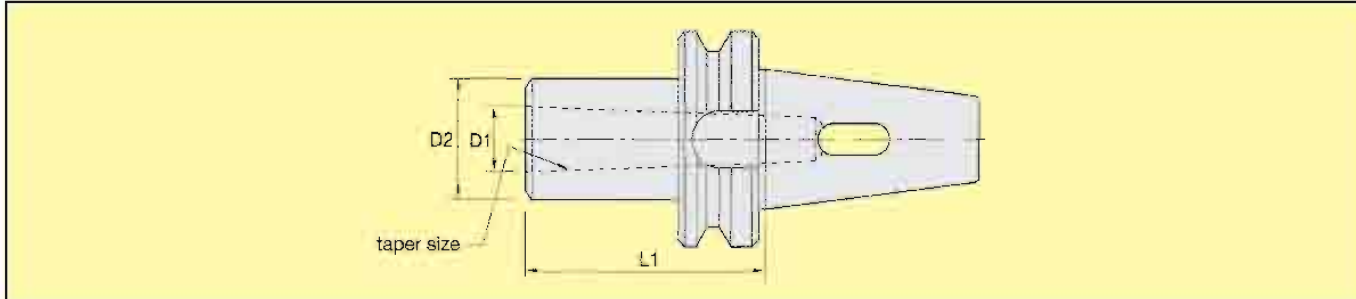

- Balance by Design, No through coolant capability, Form-AD
- Recommended for tools with a morse taper and tang
- Order Example – BT40MT1050M

Catalogue No.	Taper Size	D1	D2	L1	Wt. Kg.
BT40MT1050M	1	12.1	25	50	1.01
BT40MT2050M	2	17.8	32	50	1.06
BT40MT3070M	3	23.80	40	70	1.13
BT40MT4095M	4	31.3	48	95	1.33

Hydraulic Chucks - Inch

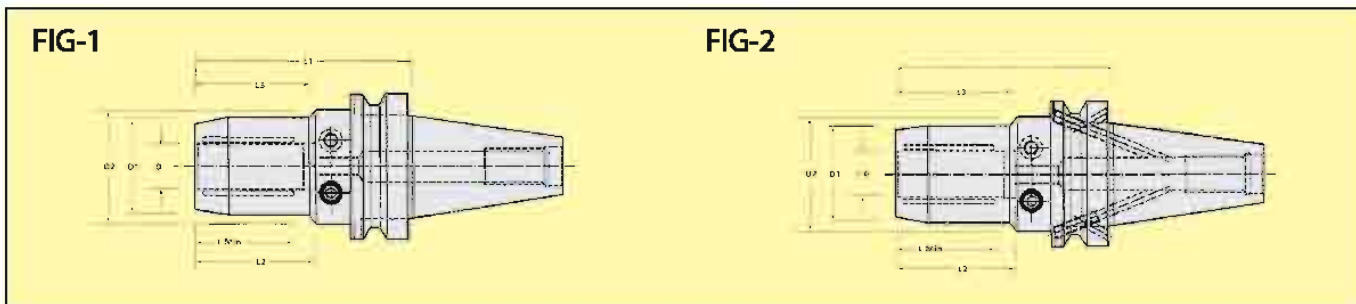

- Pre Balanced G6.3 @ 15,000 rpm, Through tool holder coolant capability
- Order Example – BT40-SHYD075-374
- Dynamically balanced to G2.5 at 20,000 rpm available on request
- Order Example – BT40-SHYD075-374-G2.5

Flange through coolant Form B/AD available on request
Order Example – BT40-SHYD075-374

Hydraulic Chucks – Inch

Catalogue No.	D	D1	D2	L1	L2	L3	L Min.	Pressure Screw	Stop Screw	Wt. Kg.
BT40-SHYD075-374	¾"	42	50	3.74"	52	50	43	SHYDC-0717	CSS-0815M	3.50
BT40-SHYD100-450	1.0"	53		4.50"	59		46	SHYDC-0720	CSS-1015M	4.81

BT40 Shank Tools

MAS 403, JIS B 6339



Shell Mill Adapters - Inch

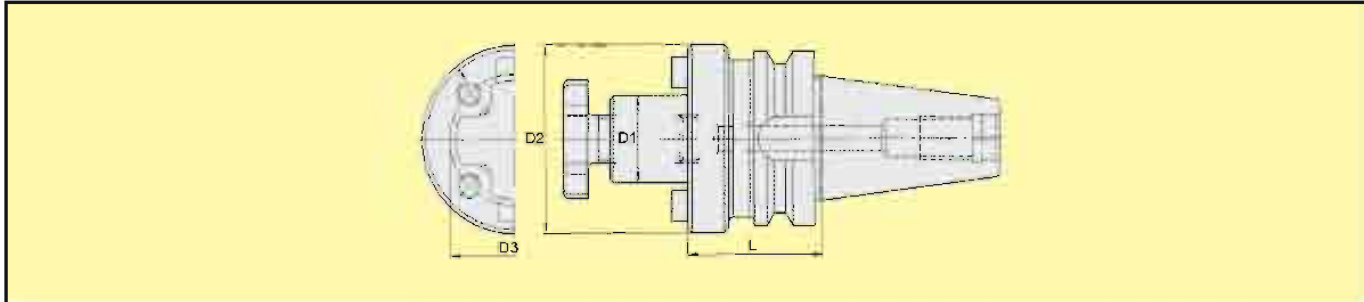

- Balanced by Design, Through tool holder coolant capability, Form-AD
- Order Example – BT40SM050177

Shell Mill Adapters – Inch

Catalogue No.	D1	D2	L	Wt. Lbs	Lock Screw	Wrench	Drive Key
BT40SM050177	1/2	1.44	1.77	2.47	BKLS05	3/16	BKDK04
BT40SM075177	3/4	1.75	1.77	2.90	BKLS07	1/4	BKDK05
BT40SM100177	1.00	2.19	1.77	3.04	BKLS10	5/16	BKDK06
BT40SM125236	1.25	2.88	2.36	4.82	BKLS12	5/16	BKDK08
BT40SM150236	1.50	3.82	2.36	4.69	BKLS15	3/8	BKSA62PKG

Jacobs Taper Adapters

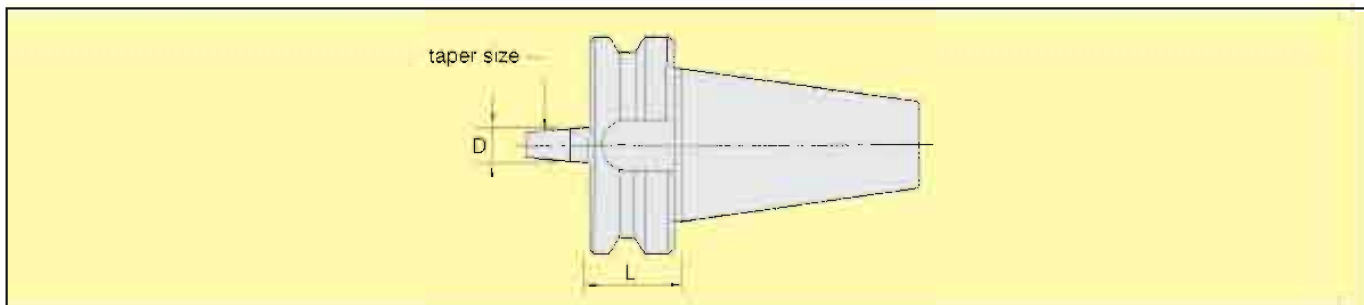

- Balance by Design
- Recommended for tools with a Jacobs internal taper
- No through-coolant capability
- Order Example – BT40JT33045M

Catalogue No.	Taper Size	D	L	Wt. Kg
BT40JT33045M	33	15.88	45	1.12
BT40JT2244	2	0.56	2.44	2.33
BT40JT3318	3	0.812	3.18	2.5
BT40JT4118	4	1.124	1.18	2.55
BT40JT6118	6	0.676	1.18	2.78

BT50 Shank Tools

MAS 403, JIS B 6339



ER Collet Chucks

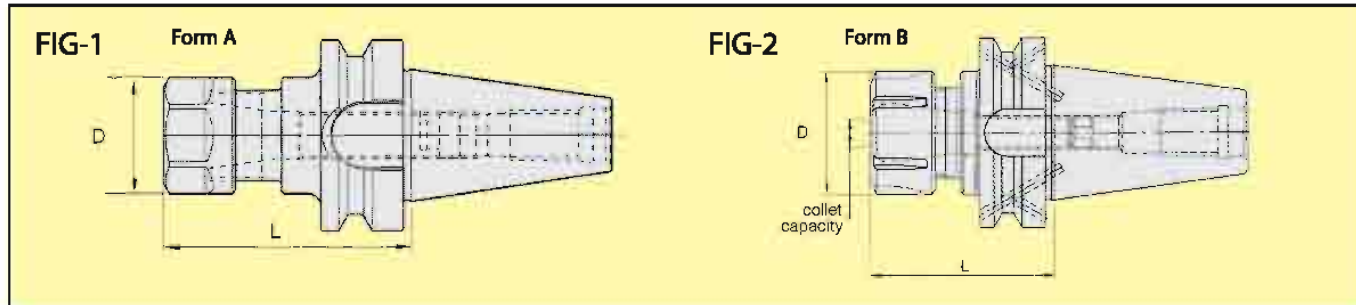

- Balanced by Design, Through tool holder coolant capability Flange through coolant Form B/AD available on request
- Order Example – BT50ER16100M Order Example – BT50BER16100M
- Dynamically balanced to G6.3 @ 15,000 rpm, & G2.5 at 20,000 rpm, available on request
- Order Example – BT50ER16100M-G2.5

ER Collet Chucks

Catalogue No. Series	Collet Min.-Max.	Collet Cap	Fig	D	L	Wt. Kg.	Locknut	Wrench	Stop Screw
BT50ER16100M	16ER	0.5 - 10	1	28	100	3.2	LNHER16M	OEW25M	BSS044038G
BT50ER16150M	16ER	0.5 - 10	1	28	150	3.6	LNHER16M	OEW25M	BSS044038G
BT50ER32070M	32ER	2 - 20	2	50	70	3.4	LNER32M	ER32WM	BSS094041G
BT50ER40080M	40ER	3 - 26	2	63	80	3.6	LNER40M	ER40WM	BSS112041G

TG Collet Chucks

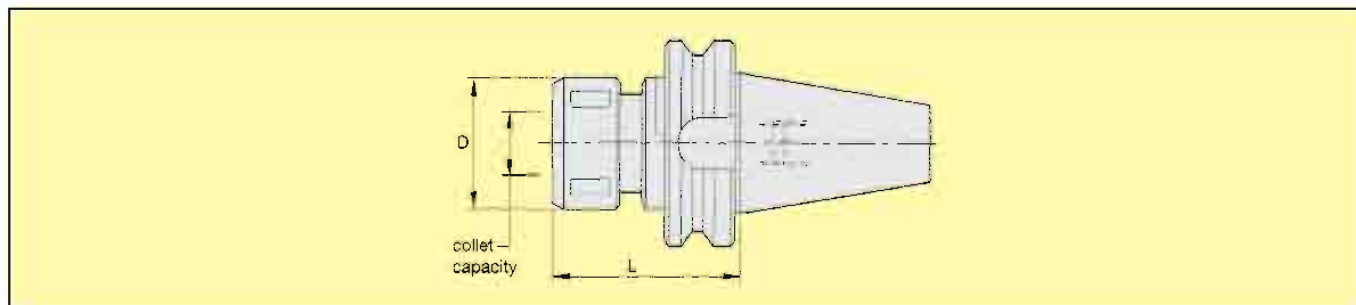

- Tremendous grip, Balanced by Design, Through tool holder coolant capability
- Order Example – BT50TG100090M
- Dynamically balanced to G6.3 @ 15,000 rpm, & G2.5 at 20,000 rpm available on request
- Order Example – BT50TG100090M-G2.5
- Flange through coolant Form B/AD available on request
- Order Example – BT50BTG100090M

TG Collet Chucks

Catalogue No.	Collet Series	Collet Cap Min.-Max.	D	L	Wt. Kg.	Locknut	Wrench	Stop Screw
BT50TG100090M	100TG	2.6 - 25.5	60	90	3.90	LNA100M	HSW58M	BSS112041G
BT50TG100150M	100TG	2.6 - 25.5	60	150	5.20	LNA100M	HSW58M	BSS112041G
BT50TG150100M	150TG	11.6 - 40	85	100	4.30	LNA150M	HSW80M	BSS162062G

BT50 Shank Tools

MAS 403, JIS B 6339



End Mill Adapters - Inch

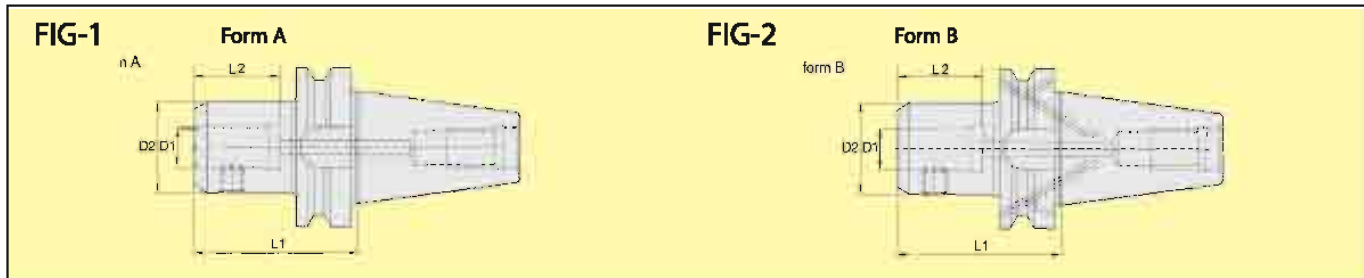

- Balanced by Design, Through tool holder coolant capability
 - Order Example – BT50EM050295
 - Dynamically balanced G6.3 @ 15,000 rpm & G2.5 at 20,000 rpm available on request
 - Order Example – BT50EM050295-G2.5
- Flange through coolant Form B/AD available on request
Order Example – BT50EM050295

End Mill Adapters – Inch

Catalogue No.	FIG	D1	D2	L1	L2	Wt. Lbs	Clamping Screw	No. of Clamp Screw	Wrench Allen Key
BT50EM050295	1	1/2	1.38	2.95	5.16	8.14	BELS044038PKG	1	7/32
BT50EM075295	1	3/4	1.75	2.95	5.16	8.36	BELS062050PKG	1	5/16
BT50EM100413	1	1	2.00	4.13	2.56	9.30	BELS075056PKG	2	3/8
BT50EM100600	1	1	2.00	6.00	4.30	10.54	BELS075056PKG	2	3/8
BT50EM125413	1	1 1/4	2.50	4.13	2.51	10.23	BELS075062PKG	2	3/8
BT50EM125600	1	1 1/4	2.50	6.00	2.51	12.54	BELS075062PKG	2	3/8
BT50EM150413	1	1 1/2	2.75	4.13	2.93	10.41	BELS075062PKG	2	3/8
BT50EM200531	1	2	3.75	5.31	3.53	16.00	BELS100088PKG	2	1/2

Drill Chucks

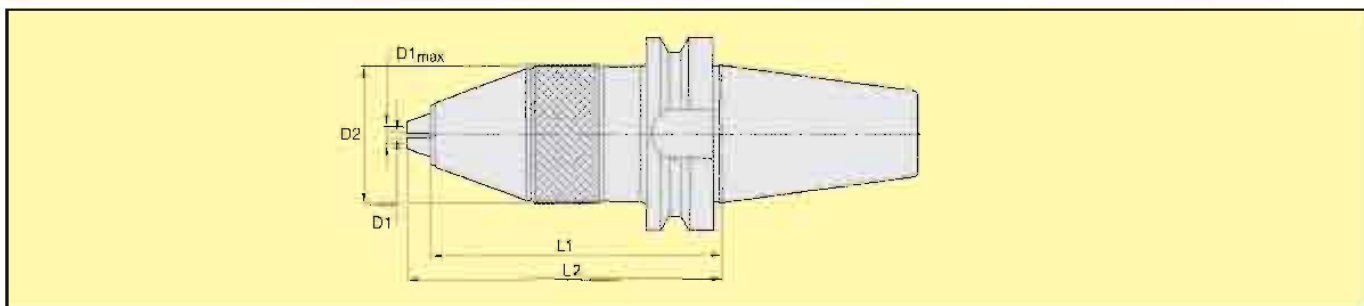

- Balance by Design
- Order Example – BT50DC13110M

Catalogue No.	D1 Min.-Max.	D2	L1	L2	Wt. Kg.	Wrench
BT50DC13110M	1 - 13	50.5	110.40	122.50	4.40	135

BT50 Shank Tools

MAS 403, JIS B 6339



Morse Taper Adapters

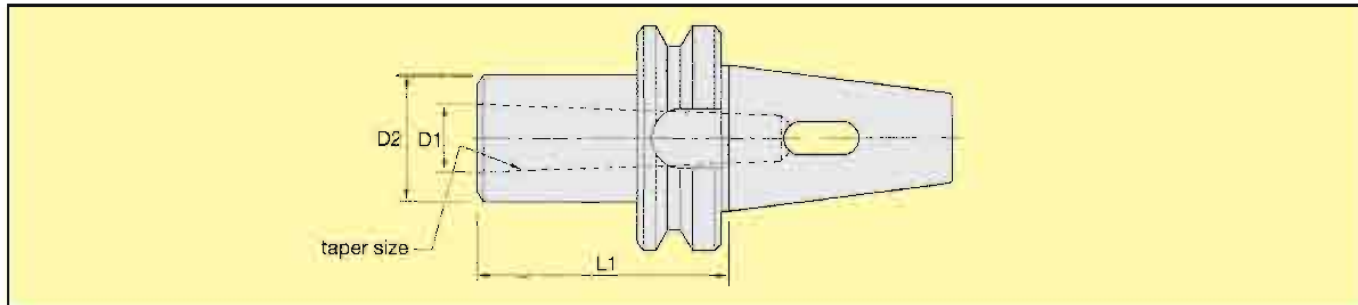

- Balance by Design, No through coolant capability, Form-AD
- Recommended for tools with a morse taper and tang
- Order Example – BT50MT1045M

Catalogue No.	Taper Size	D1	D2	L1	Wt. Kg
BT50MT1045M	1	12.10	25	45	1.8
BT50MT3065M	3	23.80	40	65	3.2
BT50MT4095M	4	31.30	48	95	3.5
BT50MT5015M	5	44.40	70	105	4.5

Hydraulic Chucks - Inch

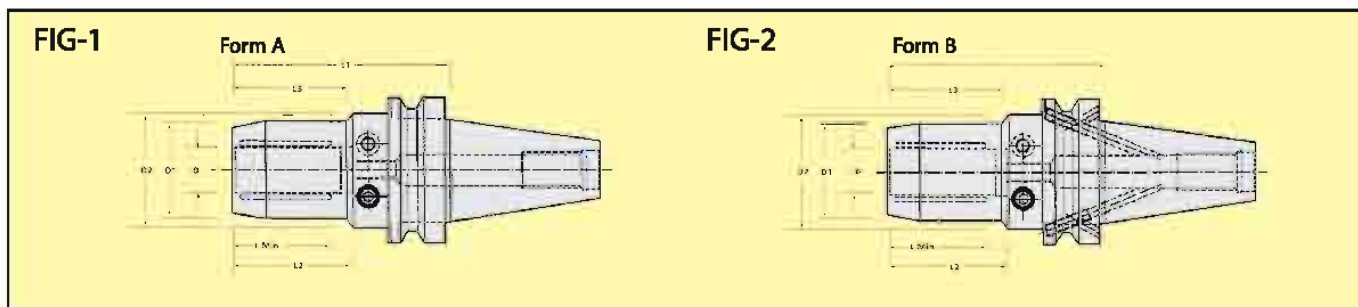

- Pre Balanced G6.3 @ 15,000 rpm
- Through tool holder coolant capability
- Order Example – BT50-SHYD100-453
- Dynamically balanced to & G2.5 at 20,000 rpm available on request
- Order Example – BT50-SHYD100-453-G2.5

Flange through coolant Form B/AD available on request
Order Example – BT50-SHYD100-453

Hydraulic Chuck – Inch

Catalogue No.	D	D1	D2	L1	L2	L3	L Min.	Pressure Screw	Stop Screw	Wt. Kg
BT50-SHYD100-453	1.0"	53	63	4.53"	59		46	SHYDC-0720	CSS-1015M	4
BT50-SHYD125-472	1 ¼"	60	63	4.72"	60		51	HYDC-1020	CSS-1015M	4

BT50 Shank Tools

MAS 403, JIS B 6339



Shell Mill Adapters - Inch

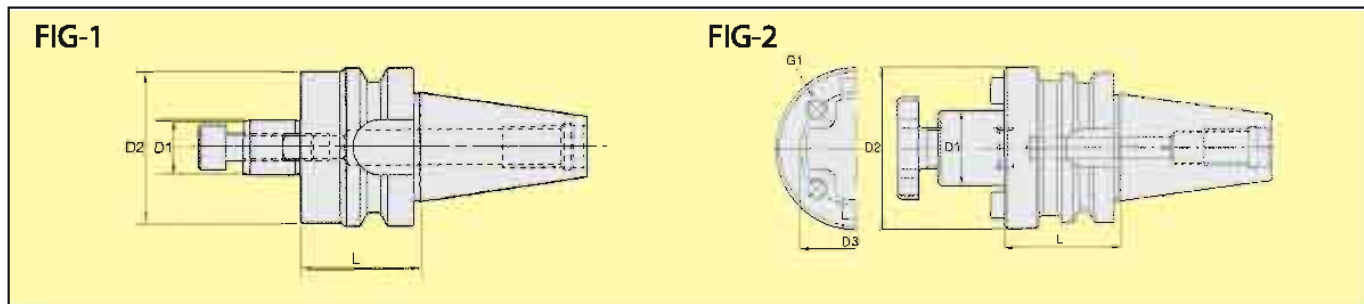

- Balanced by Design, Through tool holder coolant capability, Form-AD
- Order Example – BT50SM075177

Shell Mill Adapters – Inch

Catalogue No.	FIG	D1	D2	D3	L	G1	Wt.Lbs	Lock Screw	Wrench	Drive Key
BT50SM075177	1	¾	1.75		1.77		8.08	BKLS07	1/4	BKDK05
BT50SM075400	1	¾	1.75		4.00		9.56	BKLS07	1/4	BKDK05
BT50SM100177	1	1.00	2.19		1.77		8.30	BKLS10	5/16	BKDK06
BT50SM100400	1	1.00	2.40		4.00		11.06	BKLS10	5/16	BKDK06
BT50SM125400	1	1.25	2.88		4.00		12.80	BKLS12	5/16	BKDK08
BT50SM150177	1	1.50	3.81		1.77		9.40	BKLS15	3/8	BKDK10
BT50SM150400	1	1.50	3.81		4.00		16.60	BKLS15	3/8	BKDK10
BT50SM200236	1	2	4.13		2.36		14.07	BLKS20	9/16	KSA75PKG
BT50SM200400	2	2	4.88	4.0	4.00	5/8-11 UNC	19.32	BKLS20	9/16	BKDK12
BT50SM250400	2	2.50	4.88	4.0	4.00	5/8- 11 UNC	20.20	S388	½	BKDK16

CV40 Shank Tools

Caterpillar (inch) CV ANSI B5.50 / ISO 7388



ER Collet Chucks - Inch

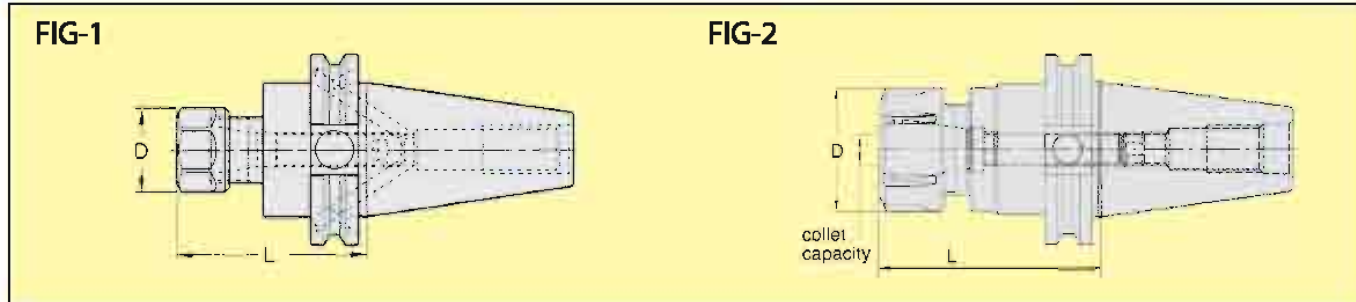

- Balanced by Design, Through tool holder coolant capability Flange through coolant Form B/AD available on request
- Order Example – CV40ER16250 Order Example – CV40BER16250
- Dynamically balanced to G6.3 @ 15,000 rpm, & G2.5 at 20,000 rpm available on request
- Order Example – CV40ER16250-G2.5

ER Collet Chucks – Form AD

Catalogue No.	Collet Series	Collet Cap Min.-Max.	Fig	D	L	Wt. Lbs	Locknut	Wrench	Stop Screw
CV40ER16250	16ER	0.02 – 0.41	1	1.10	2.50	2.4	LNHER16M	OEW25M	BSS044038G
CV40ER16500	16ER	0.02 – 0.41	1	1.10	5.00	3.2	LNHER16M	OEW25M	BSS044038G
CV40ER20250	20ER	0.02 – 0.50	1	1.34	2.50	2.4	LNHER20M	OEW30M	BSS056041G
CV40ER20600	20ER	0.02 – 0.50	1	1.34	6.00	3.7	LNHER20M	OEW30M	BSS056041G
CV40ER25250	25ER	0.04 – 0.63	2	1.65	2.50	2.6	LNER25M	ER25WM	BSS075041G
CV40ER25600	25ER	0.04 – 0.63	2	1.65	6.00	4.4	LNER25M	ER25WM	BSS075041G
CV40ER32275	32ER	0.04 – 0.81	2	1.97	2.75	2.6	LNER32M	ER32WM	BSS094041G
CV40ER32600	32ER	0.04 – 0.81	2	1.97	6.00	4.4	LNER32M	ER32WM	BSS094041G
CV40ER40300	40ER	0.12 – 1.00	2	2.48	3.00	3.0	LNER40M	ER40WM	BSS112041G
CV40ER40600	40ER	0.12 – 1.00	2	2.48	6.00	3.0	LNER40M	ER40WM	BSS112041G

ER Short – CV Form AD

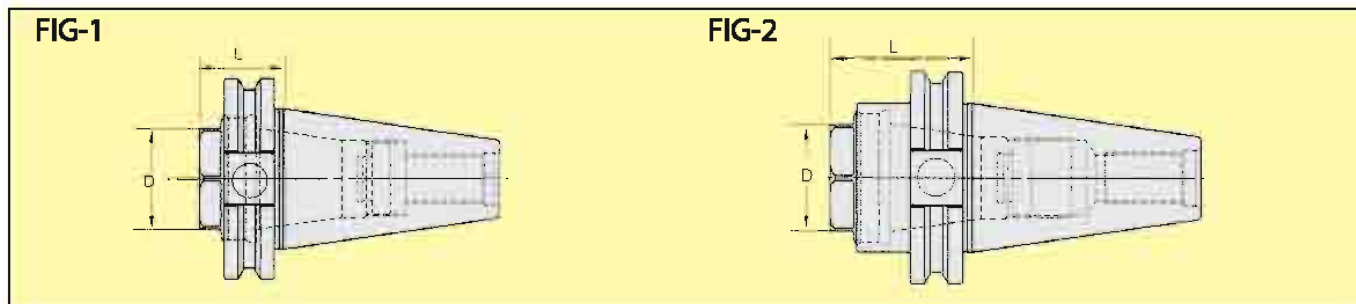

Catalogue No.	Collet Series	Collet Cap Min.-Max.	Fig	D	L	Wt. Lbs	Locknut	Wrench	Stop Screw
CV40ZSER32106	32ER	0.08 - 0.81	1	1.41	1.06	1.4	LNECSER32M	OEW32M	BSS094041G
CV40SER32169	32ER	0.08 - 0.81	2	1.41	1.69	1.7	LNECSER32M	OEW32M	BSS094041G

CV 40 Shank Tools

Caterpillar (inch) CV ANSI B5.50 / ISO 7388



TG Collet Chucks – Inch

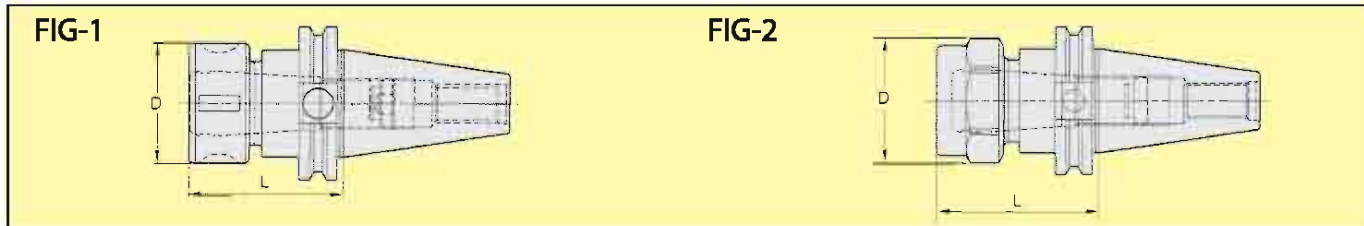

- Balanced by Design, Through tool holder coolant capability
 - Order Example – CV40TG075254G
 - Dynamically balanced to & G6.3 @ 15,000 rpm & G2.5 at 20,000 rpm available on request
 - Order Example – CV40TG075254G-G2.5
- Flange through coolant Form B/AD available on request
Order Example – CV40BTG075254G

Catalogue No.	Collet Series	Collet Cap Min.-Max.	Fig	D	L	Wt. Lbs	Locknut	Wrench	Stop Screw
CV40TG075254G	75TG	3/64 – 3/4	1	1.97	2.54	2.50	LNA075M	HSW45M	BSS081041G
CV40TG075275	75TG	3/64 – 3/4	2	2.09	2.75	2.41	NPA075M	OEW188M	BSS081041G
CV40TG075579G	75TG	3/64 – 3/4	1	1.97	5.79	4.40	LNA075M	HSW45M	BSS081041G
CV40TG075600	75TG	3/64 – 3/4	2	2.09	6.00	4.40	NPA075M	OEW188M	BSS081041G
CV40TG075800G	75TG	3/64 – 3/4	1	1.97	8.00	5.54	LNA075M	HSW45M	BSS081041G
CV40TG100300	100TG	5/64 - 1	2	2.44	3.00	2.77	NPA100M	OEW225	BSS112041G
CV40TG100400	100TG	5/64 - 1	2	2.44	4.00	3.28	LNPA100M	OEW225	BSS112041G
CV40TG100276G	100TG	5/64 - 1	1	2.36	2.76	2.69	LNA100M	HSW58M	BSS112041G
CV40TG100376G	100TG	5/64 - 1	1	2.36	3.76	3.23	LNA100M	HSW58M	BSS112041G
CV40TG100576G	100TG	5/64 - 1	1	2.36	5.76	5.52	LNA100M	HSW58M	BSS112041G
CV40TG100600	100TG	5/64 - 1	2	2.44	6.00	5.4	NPA100M	OEW225	BSS112041G
CV40TG150488	150TG	23/64 – 1 1/2	1	3.50	4.88	5.72	NPA150M	PSW350	BSS125050G

DA Collet Chucks - Inch

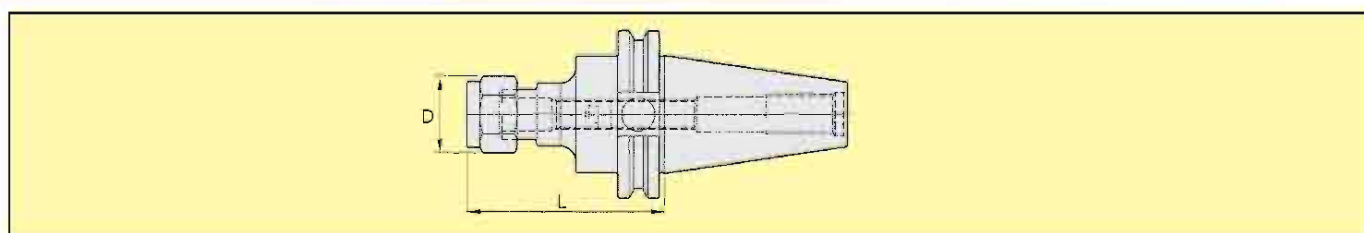

- Balanced by Design, Through tool holder coolant capability
Order Example – CV40DA208300,
Dynamically balanced to G6.3 @ 15,000 rpm, & G2.5 at 20,000 rpm available on request
Order Example – CV40DA208300-G2.5
Flange through coolant Form B/AD available on request Order Example – CV40BDA208300

Catalogue No.	Collet Series	Collet Cap Min.-Max.	D	L	Wt. Lbs	Locknut	Wrench	Stop Screw
CV40DA208300	200DA	1/64 – 25/64	1.15	3.00	2.41	NPA208	OEW100	BSS044038G
CV40DA208500	200DA	1/64 – 25/64	1.15	5.00	3.05	NPA208	OEW100	BSS044038G
CV40DA188300	180DA	1/64 – 3/4	1.73	3.00	2.42	NPA188	OEW150	BSS081041G
CV40DA188600	180DA	1/64 – 3/4	1.73	6.00	3.6	NPA188	OEW150	BSS081041G

CV 40 Shank Tools

Caterpillar (inch) CV ANSI B5.50 / ISO 7388



End Mill Adapters – Inch

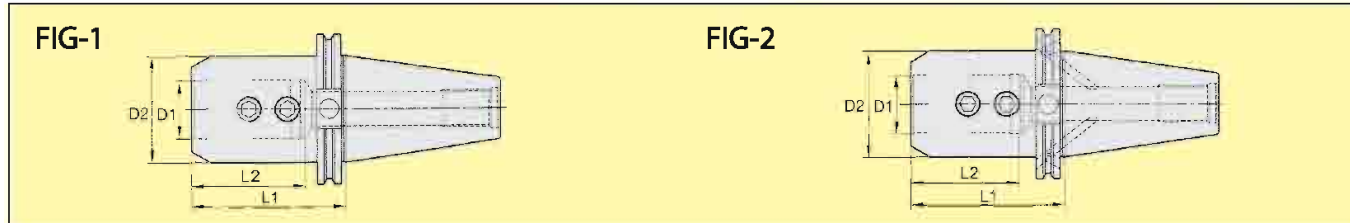

- Balanced by Design, Through tool holder coolant capability Flange through coolant Form B/AD available on request
- Order Example – CV40ZEM012138 Order Example – CV40BEM050262
- Dynamically balanced to G6.3 @ 15,000 rpm, G2.5 at 20,000 rpm available on request
- Order Example – CV40ZEM012138-G2.5

Catalogue No.	FIG	D1	D2	L1	L2	Wt. Lbs	Clamping Screw	No of lamp Screw	Wrench Allen Key
CV40ZEM012138	1	1/8	0.69	1.38	2.89	1.79	BS1045PKG	1	3/32
CV40EM012450	1	1/8	0.69	4.50	6.01	2.41	BS1045PKG	1	3/32
CV40ZEM018138	1	3/16	0.69	1.38	2.89	1.79	BS1045PKG	1	3/32
CV40EM018250	1	3/16	0.69	2.50	4.01	2.22	BS1045PKG	1	3/32
CV40EM018450	1	3/16	0.69	4.50	6.01	2.41	BS1045PKG	1	3/32
CV40ZEM025138	1	1/4	0.78	1.38	2.89	1.82	BELS025025PKG	1	1/8
CV40EM025250	1	1/4	1.00	2.50	4.01	2.35	BELS025025PKG	1	1/8
CV40EM025450	1	1/4	0.78	4.50	6.01	2.51	BELS025025PKG	1	1/8
CV40ZEM031138	1	5/16	1.00	1.38	2.89	1.85	BELS031031PKG	1	5/32
CV40EM031450	1	5/16	1.00	4.50	6.01	2.76	BELS031031PKG	1	5/32
CV40ZEM038138	1	3/8	1.00	1.38	2.89	1.85	BELS038031PKG	1	3/16
CV40EM038250	1	3/8	1.00	2.50	4.01	2.32	BELS038031PKG	1	3/16
CV40EM038450	1	3/8	1.00	4.50	6.01	2.69	BELS038031PKG	1	3/16
CV40EM038650	1	3/8	1.00	6.50	8.01	3.17	BELS038031PKG	1	3/16
CV40ZEM044175	1	7/16	1.25	1.75	3.26	2.00	BELS044038PKG	1	7/32
CV40EM044450	1	7/16	1.25	4.50	6.01	3.04	BELS044038PKG	1	7/32
CV40ZEM050175	1	1/2	1.75	1.75	3.26	2.27	BELS044038PKG	1	7/32
CV40EM050262	1	1/2	1.38	2.62	4.13	2.52	BELS044038PKG	1	7/32
CV40EM050462	1	1/2	1.25	4.62	6.13	3.05	BELS044038PKG	1	7/32
CV40EM050662	1	1/2	1.25	6.62	8.13	3.83	BELS044038PKG	1	7/32
CV40ZEM062175	1	5/8	1.75	1.75	3.56	2.19	BELS056050PKG	1	1/4
CV40EM062375	1	5/8	1.50	3.75	3.56	2.96	BELS056038PKG	1	1/4
CV40EM062575	1	5/8	1.63	5.75	3.56	4.21	BELS056050PKG	1	1/4
CV40ZEM075175	1	3/4	1.75	1.75	2.40	2.09	BELS062050PKG	1	5/16
CV40EM075375	1	3/4	1.75	3.75	3.94	3.21	BELS062050PKG	1	5/16
CV40EM075575	1	3/4	1.75	5.75	3.94	4.44	BELS062050PKG	1	5/16
CV40ZEM088175	1	7/8	1.88	1.75	2.27	2.31	BELS062050PKG	1	5/16
CV40EM088400	1	7/8	2.00	4.00	4.19	3.65	BELS062050PKG	1	5/16
CV40EM088600	1	7/8	1.88	6.00	4.19	4.86	BELS062050PKG	1	5/16
CV40ZEM100175	1	1	1.75	1.75	2.64	1.78	DWG ELS075044	2	3/8
CV40EM100400	1	1	2.00	4.00	4.43	3.39	BELS075056PKG	2	3/8
CV40EM100600	1	1	2.00	6.00	4.43	5.04	BELS075056PKG	2	3/8
CV40ZEM125200	1	1 1/4	2.25	2.00	2.35	2.25	BDWG ELS075044	2	3/8
CV40EM125425	1	1 1/4	2.50	4.25	2.39	4.96	BELS075062PKG	2	3/8
CV40EM125625	1	1 1/4	2.50	6.25	2.39	7.47	BELS075062PKG	2	3/8
CV40EM150462	1	1 1/2	2.75	4.63	2.82	5.80	BELS075069PKG	2	3/8
CV40EM150662	1	1 1/2	2.75	6.63	2.82	8.76	BELS075069PKG	2	3/8

CV 40 Shank Tools

Caterpillar (inch) CV ANSI B5.50 / ISO 7388



Drill Chucks

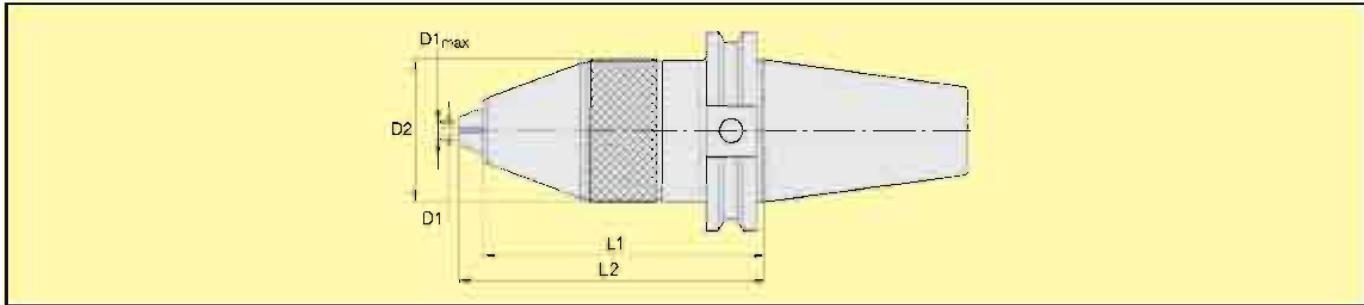

- Balance by Design, No through coolant capability
- Order Example – CV40DC13M421

Catalogue No.	D1 Min.-Max.	D2	L1	L2	Wt. Lbs	Wrench
CV40DC13M421	0.39 – 0.512	1.89	4.04	4.50	3.84	13S.

Morse Taper Adapters - Inch

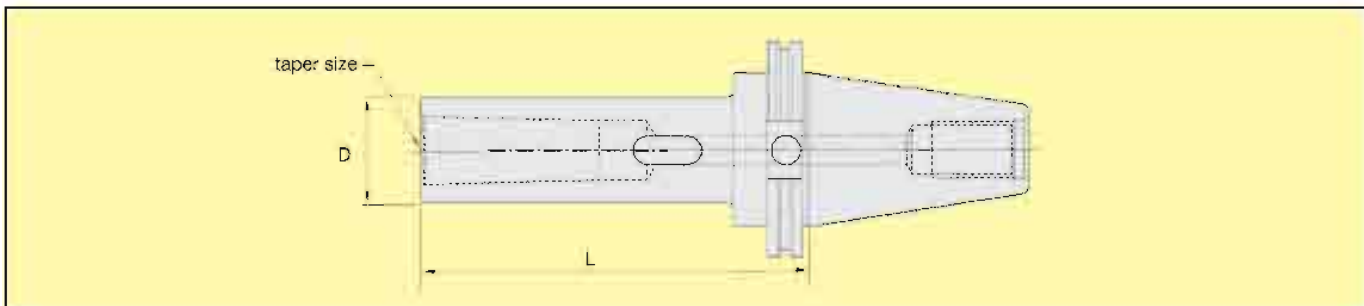

- Balance by Design, No through coolant capability
- Recommended for tools with a morse taper and tang
- Order Example – CV40MT1175

MT – CV Form-A

Catalogue No.	Taper Size	D	L	Wt. Lbs
CV40MT1175	1	0.980	1.750	2.21
CV40MT2244	2	1.260	2.440	2.30
CV40MT3300	3	1.570	3.000	2.49
CV40MT4388	4	1.890	3.880	2.86

CV 40 Shank Tools

Caterpillar (inch) CV ANSI B5.50 / ISO 7388



Hydraulic Chucks - Inch

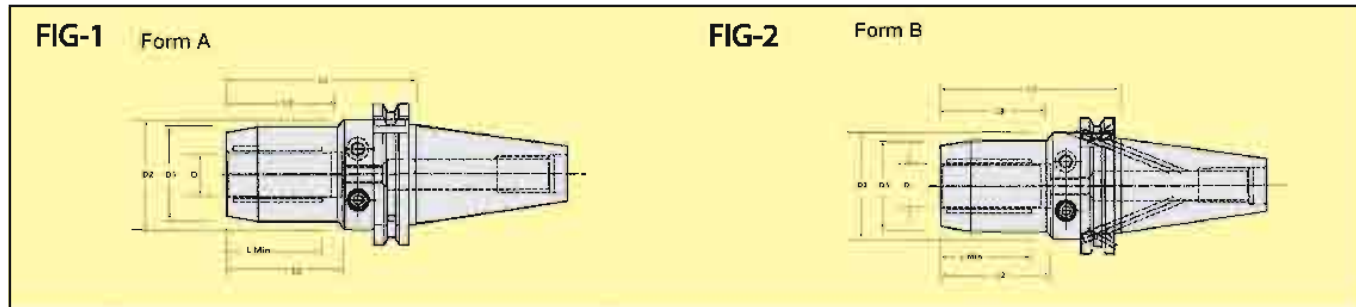

- Pre Balanced G6.3 @ 15,000 rpm
- Through tool holder coolant capability
- Order Example – CV40B-SHYD075-400
- Dynamically balanced to G2.5 at 20,000 rpm available on request
- Order Example – CV40B-SHYD075-400-G2.5

Flange through coolant Form B/AD available on request
Order Example – CV40B-SHYD075-400

Hydraulic Chucks – Inch Form B/AD

Catalogue No.	D	D1	D2	L1	L2	L3	L Min.	Pressure Screw	Stop Screw	Wt. Lbs
CV40B-SHYD075-400	¾"	42	50	4.00"	52	50	43	SHYDC-0717	CSS-0815M	3.53
CV40B-SHYD100-462	1.0"	53		4.62"	59		46	SHYDC-0720	CSS-1015M	4.76

Boring Bar Blank - Inch

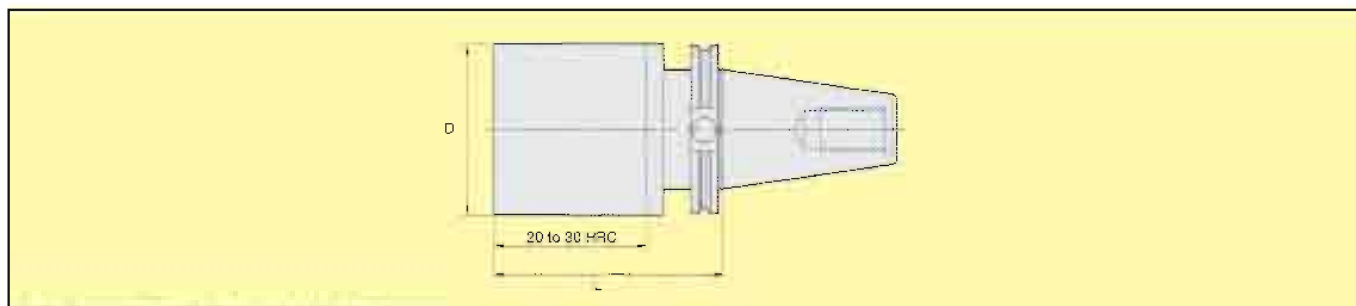

- Balance By Design, Machinable front end 20-30 HRC, 5/8"- 11 UNC Draw Bar Thread
- Order Example – CV40BB4001200

Catalogue No.	D2	L1	Wt. Lbs
CV40BB4001200	4.00"	12,00"	39.89
CV40BB400600	4,00"	6,00"	18.55

CV 40 Shank Tools

Caterpillar (inch) CV ANSI B5.50 / ISO 7388



Shrink Fit Adapters – Inch

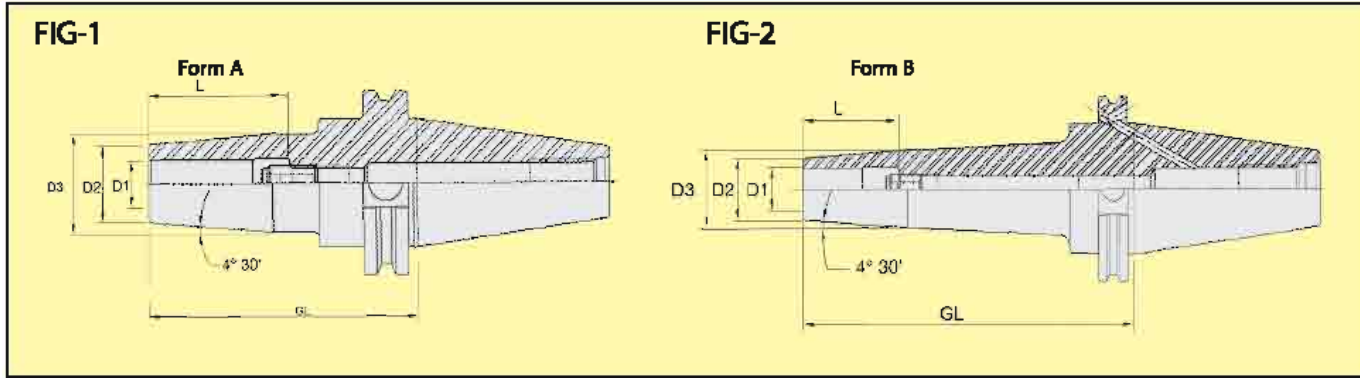

- Pre Balanced G6.3 @ 15,000 rpm,
- Through tool holder coolant capability
- Suitable for carbide & HSS Cutting tool,
- Runout < 0,003mm (0,0001"),
- 10mm (3/8") axial adjustment.
- Order Example – CV40BSF025350
- Dynamically balanced to G2.5 at 20,000 rpm available on request
- Order Example – CV40BSF025350-G2.5

Flange through coolant Form B/AD available
Order Example – CV40BSF025350

Catalogue No.	FIG	D1	D2	D3	GL	L	Wt. Lbs	Stop Screw
CV40BSF025350	1	1/4	0.83	1.06	3.50	1.41	2.51	BTTSS05014M
CV40BSF025600	2	1/4	0.83	1.06	6.00	1.41	3.18	BTTSS05014M
CV40BSF031350	1	5/16	0.83	1.06	3.50	1.41	2.49	BTTSS06014M
CV40BSF031600	2	5/16	0.79	1.06	6.00	1.41	3.18	BTTSS06014M
CV40BSF038375	1	3/8	0.94	1.26	3.75	1.81	2.71	BTTSS08014M
CV40BSF038600	2	3/8	0.94	1.26	6.00	1.81	3.55	BTTSS08014M
CV40BSF044375	1	7/16	0.94	1.26	3.75	1.81	2.69	BTTSS10014M
CV40BSF044600	2	7/16	0.94	1.26	6.00	1.81	3.53	BTTSS10014M
CV40BSF050375	1	1/2	0.94	1.26	3.75	1.81	2.67	BTTSS10014M
CV40BSF050600	2	1/2	0.94	1.26	6.00	1.81	3.51	BTTSS10014M
CV40BSF056375	1	9/16	1.06	1.34	3.75	1.81	2.78	BTTSS10014M
CV40BSF056600	2	9/16	1.06	1.34	6.00	1.81	3.73	BTTSS10014M
CV40BSF062375	1	5/8	1.06	1.34	3.75	1.93	2.73	BTTSS12014M
CV40BSF062600	2	5/8	1.06	1.34	6.00	1.93	3.66	BTTSS12014M
CV40BSF068400	1	11/16	1.34	1.75	4.00	1.93	3.26	BTTSS12014M
CV40BSF068600	2	11/16	1.30	1.65	6.00	1.93	4.52	BTTSS12014M
CV40BSF075400	1	3/4	1.34	1.75	4.00	2.00	3.22	BTTSS16014M
CV40BSF075600	2	3/4	1.30	1.65	6.00	2.00	4.45	BTTSS16014M
CV40BSF088400	1	7/8	1.34	1.75	4.00	2.00	3.09	BTTSS16014M
CV40BSF088600	2	7/8	1.30	1.65	6.00	2.00	4.37	BTTSS16014M
CV40BSF100400	1	1.00	1.73	2.08	4.00	2.24	3.73	BTTSS16014M
CV40BSF100600	2	1.00	1.73	2.08	6.00	2.24	5.62	BTTSS16014M
CV40BSF125400	1	1 1/4	1.73	2.08	4.00	2.24	3.42	BTTSS16014M
CV40BSF125600	2	1 1/4	1.73	2.08	6.00	2.24	5.34	BTTSS16014M

CV 40 Shank Tools

Caterpillar (inch) CV ANSI B5.50 / ISO 7388



Shell Mill Adapters - Inch

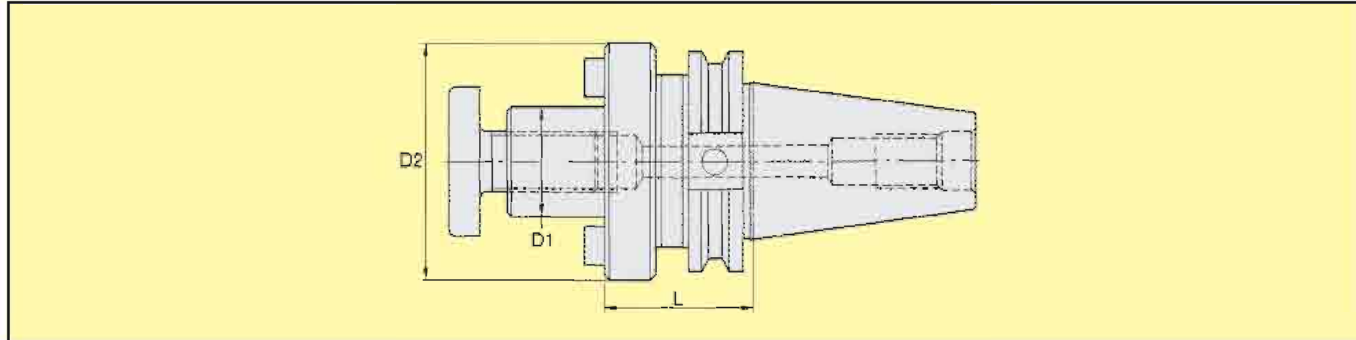

- Balanced by Design, Through the tool holder coolant capability
- Order Example – CV40SM050138

Shell Mill Adapters – Inch

Catalogue No.	D1	D2	L	Wt. Lbs	Lock Screw	Allen Key	Drive Key
CV40SM050138	1/2	1.75	1.38	2.27	BKLS05	3/16	BKDK04
CV40SM075138	3/4	1.75	1.38	2.21	BKLS07	1/4	BKDK05
CV40SM075350	3/4	1.75	3.50	3.80	BKLS07	1/4	BKDK05
CV40SM100206	1	2.19	2.06	3.10	BKLS10	5/16	BKDK06
CV40SM100400	1	2.19	4.00	4.30	BKLS10	5/16	BKDK06
CV40SM125212	1 1/4	2.75	2.12	4.00	BKLS12	5/16	BKDK08
CV40SM125400	1 1/4	2.75	4.00	5.00	BKLS12	5/16	BKDK08
CV40SM150241	1 1/2	3.38	2.41	5.01	BKLS15	3/8	BKDK10
CV40SM150400	1 1/2	3.38	4.00	6.15	BKLS15	3/8	BKDK10

Jacobs Taper Adapters - Inch

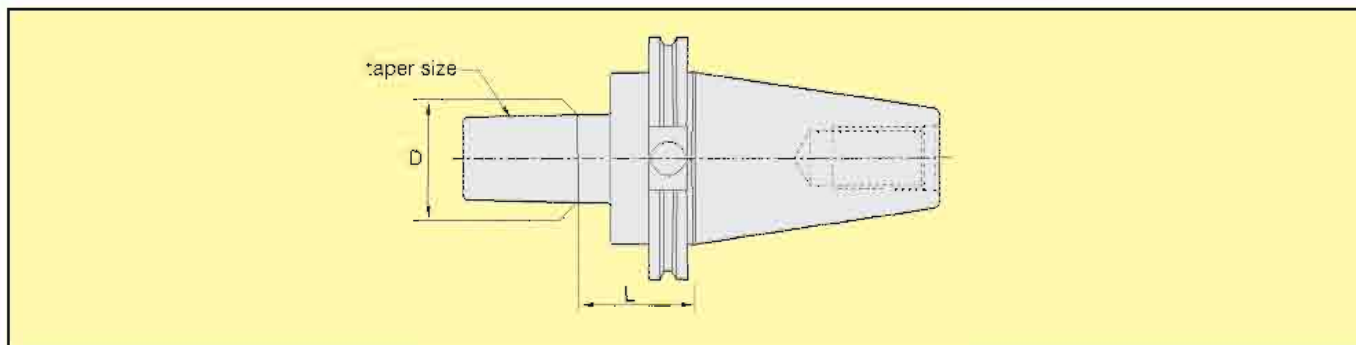

- Balance by Design, No through-coolant capability
- Recommended for tools with a Jacobs Internal taper
- Order Example – CV40JT2244

Catalogue No.	Taper Size	D	L	Wt. Lbs
CV40JT2244	2	0.560	2.440	2.33
CV40JT3278	3	0.812	2.780	2.45
CV40JT33256	33	0.625	2.560	2.32
CV40JT4244	4	1.124	2.44	2.45
CV40JT6244	6	0.676	2.44	2.78

CV 50 Shank Tools

Caterpillar (inch) CV ANSI B5.50 / ISO 7388



ER Collet Chucks - Inch

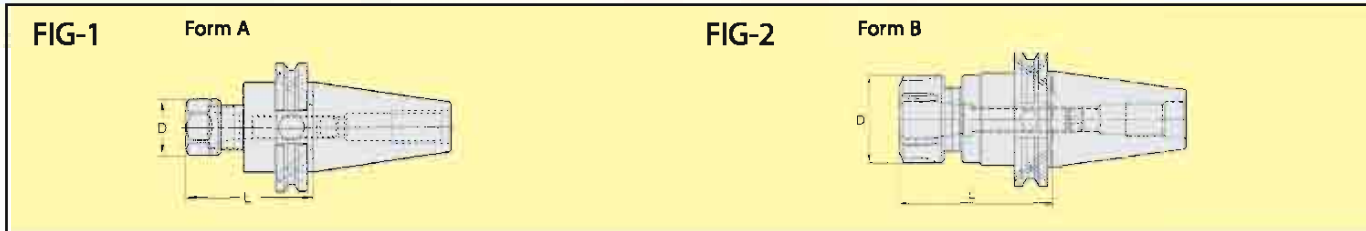

- Balanced by Design, Through tool holder coolant capability Flange through coolant Form B/AD Available
- Order Example – CV50ER16400 Order Example – CV50BER16250
- Dynamically balanced to G6.3 @ 15,000 rpm & G2.5 at 20,000 rpm available on request
- Order Example – CV50ER160400-G2.5

ER Collet Chucks Form AD

Catalogue No.	Collet Series	Collet Cap Min.-Max.	Fig	D	L	Wt. Lbs	Locknut	Wrench	Stop Screw
CV50ER16400	16ER	0.02 – 0.41	1	1.10	4.00	7.3	LNHER16M	OEW25M	BSS044038G
CV50ER16600	16ER	0.02 – 0.41	1	1.10	6.00	7.9	LNHER16M	OEW25M	BSS044038G
CV50ER20400	20ER	0.02 – 0.50	1	1.34	4.00	7.4	LNHER20M	OEW30M	BSS056041G
CV50ER20600	20ER	0.02 – 0.50	1	1.34	6.00	8.1	LNHER20M	OEW30M	BSS056041G
CV50ER25400	25ER	0.04 – 0.63	2	1.65	4.00	7.8	LNER25M	ER25WM	BSS075041G
CV50ER25600	25ER	0.04 – 0.63	2	1.65	6.00	8.8	LNER25M	ER25WM	BSS075041G
CV50ER32400	32ER	0.04 – 0.81	2	1.97	4.00	8.1	LNER32M	ER32WM	BSS094041G
CV50ER32600	32ER	0.04 – 0.81	2	1.97	6.00	9.5	LNER32M	ER32WM	BSS094041G
CV50ER40400	40ER	0.12 – 1.00	2	2.48	4.00	8.9	LNER40M	ER40WM	BSS112041G
CV50ER40600	40ER	0.12 – 1.00	2	2.48	6.00	11.8	LNER40M	ER40WM	BSS112041G

ER Short – CV Form AD - Inch

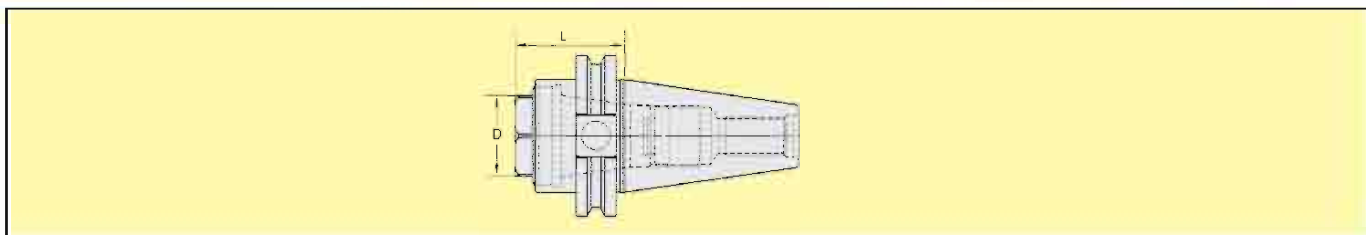

Catalogue No.	Collet Series	Collet Cap Min.-Max.	D	L	Wt. Lbs	Locknut	Wrench	Stop Screw
CV50SER32169	32ER	0.08 – 0.81	1.41	1.69	6.27	LNECER32M	OEW32M	BSS094041G

CV 50 Shank Tools

Caterpillar (inch) CV ANSI B5.50 / ISO 7388



TG Collet Chucks - Inch

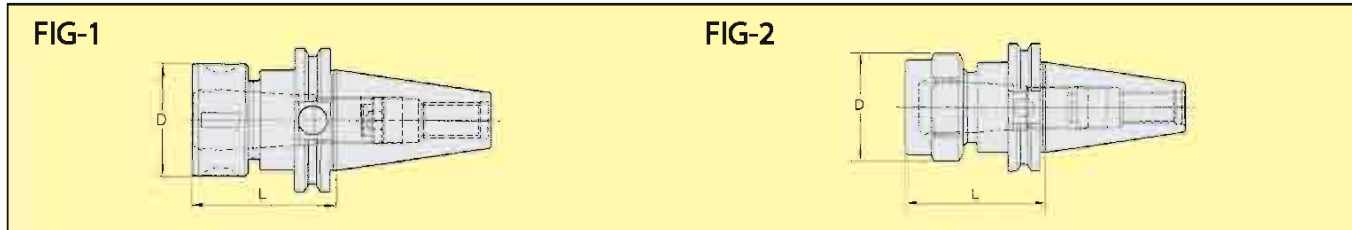

- Tremendous Grip, Balanced by Design, Through tool holder coolant capability Flange through coolant –Form B/AD
Order Example – CV50TG075254G
- Order Example – CV50TG075254G
- Dynamically balanced to G6.3 @ 15,000 rpm, & G2.5 at 20,000 rpm, available on request
- Order Example – CV50TG075254G-G2.5

Catalogue No.	Collet Series	Collet Cap Min.-Max.	Fig	D	L	Wt. Lbs	Locknut	Wrench	Stop Screw
CV50TG075254G	75TG	3/64 – 3/4	1	1.97	2.54	7.3	LNA075M	HSW45M	BSS081041G
CV50TG075275	75TG	3/64 – 3/4	2	2.09	2.75	7.3	NPA075M	OEW188M	BSS081041G
CV50TG075579G	75TG	3/64 – 3/4	1	1.97	5.79	9.70	LNA075M	HSW45M	BSS081041G
CV50TG075600	75TG	3/64 – 3/4	2	2.09	6.00	9.70	NPA075M	OEW188M	BSS081041G
CV50TG075800G	75TG	3/64 – 3/4	1	1.97	8.00	11.5	LNA075M	HSW45M	BSS081041G
CV50TG0751000G	75TG	3/64 – 3/4	1	1.97	10.0	13.6	LNA075M	HSW45M	BSS081041G
CV50TG100300	100TG	5/64 - 1	2	2.44	3.00	7.16	NPA100M	OEW225	BSS112041G
CV50TG100400	100TG	5/64 - 1	2	2.44	4.00	8.00	NPA100M	OEW225	BSS112041G
CV50TG100600	100TG	5/64 - 1	2	2.44	6.00	9.76	NPA100M	OEW225	BSS112041G
CV50TG100276G	100TG	5/64 - 1	1	2.36	2.76	7.1	LNA100M	HSW58M	BSS112041G
CV50TG100326G	100TG	5/64 - 1	1	2.36	3.26	7.61	LNA100M	HSW58M	BSS112041G
CV50TG100526G	100TG	5/64 - 1	1	2.36	5.26	9.5	LNA100M	HSW58M	BSS112041G
CV50TG150488	150TG	23/64 – 1 1/2	1	3.48	4.88	10.1	NPA150M	PSW350	BSS125050G

DA Collet Chucks - Inch

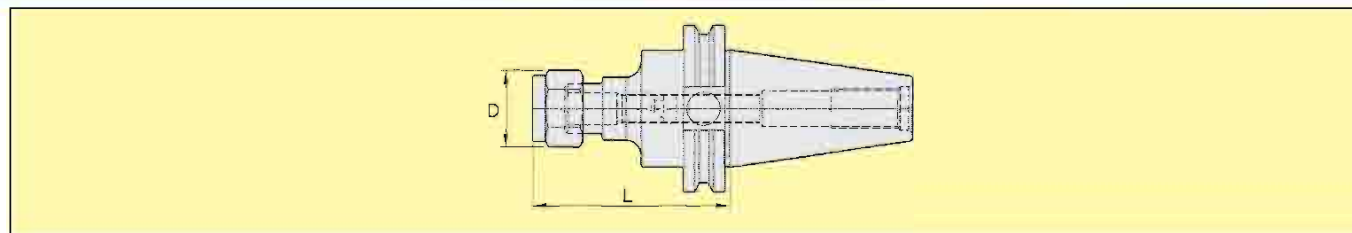

- Balanced by Design, Through tool holder coolant capability Flange through coolant Form B/AD available on request
- Order Example – CV50DA188300 Order Example – CV50BDA188300
- Dynamically balanced to G6.3 @ 15,000 rpm & G2.5 at 20,000 rpm available on request
- Order Example – CV50DA188300-G2.5

Catalogue No.	Collet Series	Collet Cap Min.-Max.	D	L	Wt. Lbs	Locknut	Wrench	Stop Screw
CV50DA188300	180DA	1/64 – 3/4	1.73	3.00	7.03	NPA188	OEW150	BSS081041G
CV50DA188600	180DA	1/64 – 3/4	1.73	6.00	8.21	NPA188	OEW150	BSS081041G

CV 50 Shank Tools

Caterpillar (inch) CV ANSI B5.50 / ISO 7388



End Mill Adapters – Inch

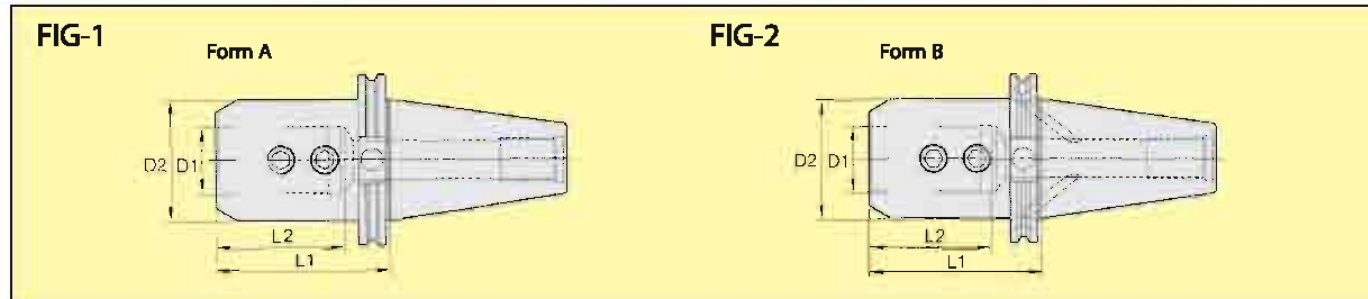

- Balanced by Design, Through tool holder coolant capability Flange through coolant Form B/AD Available on request
- Order Example – CV50EM018250 Order Example – CV50EM018250
- Dynamically balanced to G6.3 @ 15,000 rpm, & G2.5 at 20,000 rpm available on request
- Order Example – CV50EM018250-G2.5

Catalogue No.	FIG	D1	D2	L1	L2	Wt. Lbs	Clamping Screw	No of lamp Screw	Wrench Allen Key
CV50EM018250	1	3/16	0.69	2.50	4.69	6.55	BS1045PKG	1	3/32
CV50EM018450	1	3/16	0.69	4.50	6.69	6.84	BS1045PKG	1	3/32
CV50EM025250	1	1/4	0.78	2.50	4.69	6.55	BELS025025PKG	1	1/8
CV50EM025450	1	1/4	0.78	4.50	6.69	7.17	BELS025025PKG	1	1/8
CV50EM031450	1	5/16	1.00	4.50	6.69	7.15	BELS031031PKG	1	5/32
CV50EM038250	1	3/8	1.00	2.50	4.69	6.63	BELS038031PKG	1	3/16
CV50EM038450	1	3/8	1.00	4.50	6.69	7.07	BELS038031PKG	1	3/16
CV50EM038650	1	3/8	1.00	6.50	8.69	7.45	BELS038031PKG	1	3/16
CV50ZEM044175	1	7/16	1.25	1.75	3.19	4.99	BELS044038PKG	1	7/32
CV50EM044450	1	7/16	1.25	4.50	4.69	6.78	BELS044038PKG	1	7/32
CV50EM050262	1	1/2	1.38	2.62	4.81	6.82	BELS044038PKG	1	7/32
CV50EM050462	1	1/2	1.38	4.62	6.81	7.52	BELS044038PKG	1	7/32
CV50EM050662	1	1/2	1.38	6.62	8.81	8.21	BELS044038PKG	1	7/32
CV50EM062375	1	5/8	1.63	3.75	5.94	7.53	BELS056038PKG	1	1/4
CV50EM062575	1	5/8	1.63	5.75	7.94	8.63	BELS056050PKG	1	1/4
CV50EM075375	1	3/4	1.75	3.75	5.94	7.65	BELS062050PKG	1	5/16
CV50EM075575	1	3/4	1.75	5.75	7.94	8.67	BELS062050PKG	1	5/16
CV50EM088400	1	7/8	2.00	4.00	4.19	8.00	BELS062050PKG	1	5/16
CV50EM088600	1	7/8	2.00	6.00	4.31	9.44	BELS062050PKG	1	5/16
CV50EM100400	1	1	2.00	4.00	4.43	7.95	BELS075056PKG	2	3/8
CV50EM100600	1	1	2.00	6.00	4.43	9.39	BELS075056PKG	2	3/8
CV50EM125425	1	1 1/4	2.50	4.25	2.39	8.98	BELS075062PKG	2	3/8
CV50EM125625	1	1 1/4	2.50	6.25	2.39	11.42	BELS075062PKG	2	3/8
CV50EM150462	1	1 1/2	2.75	4.62	2.82	9.19	BELS075069PKG	2	3/8
CV50EM150662	1	1 1/2	2.75	6.62	2.82	12.21	BELS075069PKG	2	3/8

CV 50 Shank Tools

Caterpillar (inch) CV ANSI B5.50 / ISO 7388



Drill Chucks - Inch

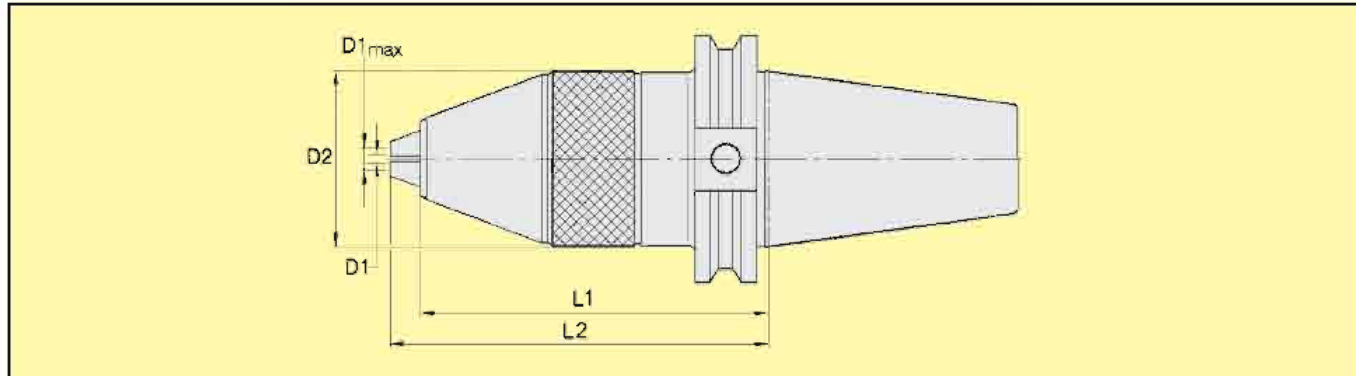

- Balance by Design, No through coolant capability
- Order Example – CV50DC13M421

Catalogue No.	D1 Min.-Max	D2	L1	L2	Wt. Lbs	Wrench
CV50DC13M421	0.39 – 0.512	1.98	4.04	4.50	7.85	135

Morse Taper Adapters - Inch

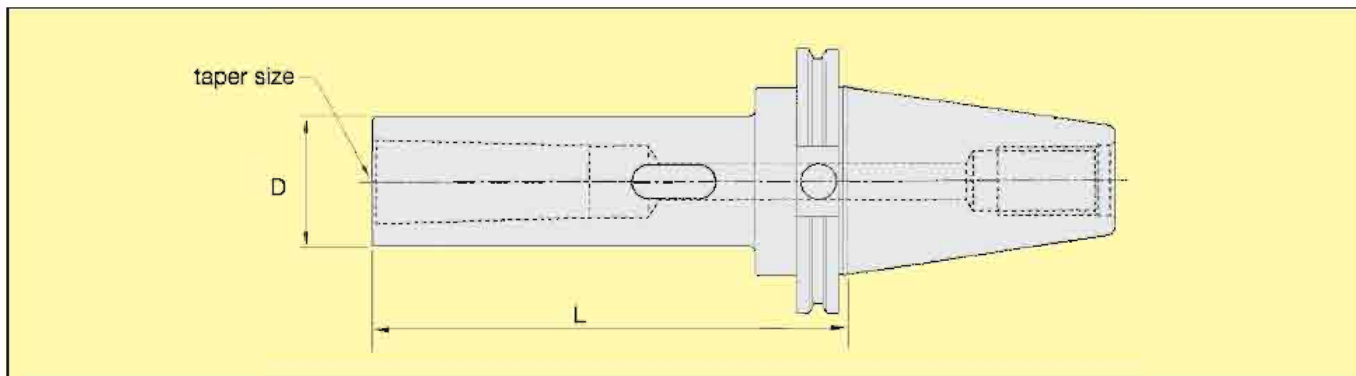

- Balance by Design, No through coolant capability
- Recommended for tools with a morse

Catalogue No.	Taper Size	D	L	Wt. Lbs
CV50MT1175	1	2.750	1.75	6.90
CV50MT2200	2	2.750	2.000	7.43
CV50MT3250	3	1.570	2.500	6.73
CV50MT4388	4	1.890	3.380	6.90
CV50MT5375	5	2.750	3.750	7.55

CV 50 Shank Tools

Caterpillar (inch) CV ANSI B5.50 / ISO 7388



Hydraulic Chucks - Inch

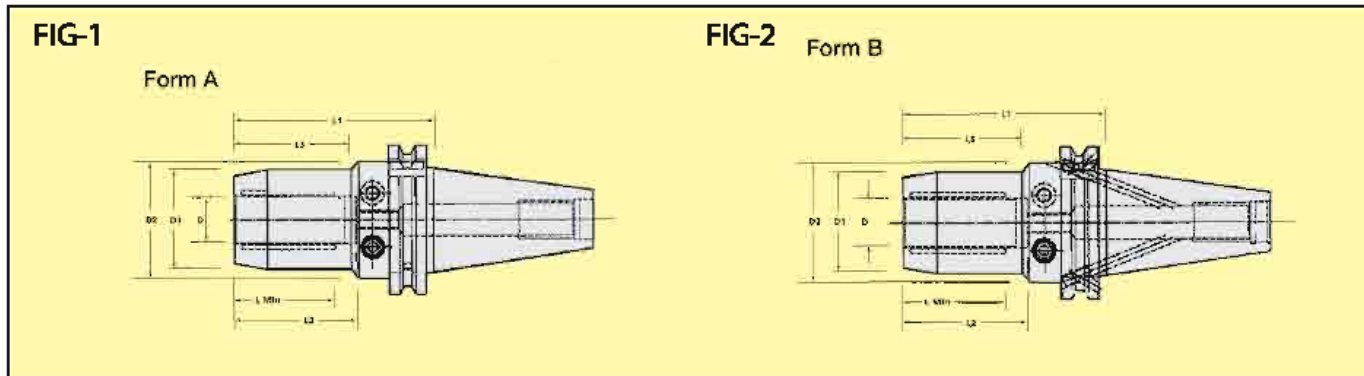

- Pre Balanced G6.3 @ 15,000 rpm,
- Through tool holder coolant capability
- Order Example – CV50B-SHYD100-462
- Dynamically balanced to G2.5 at 20,000 rpm available on request
- Order Example – CV50B-SHYD100-462-G2.5

Flange through coolant Form B/AD Available
Order Example – CV50B-SHYD100-462

Hydraulic Chucks – Inch Form B/AD

Catalogue No.	D	D1	D2	L1	L2	L3	L Min.	Pressure Screw	Stop Screw	Wt. Lbs
CV50B-SHYD100-462	1.0"	53		4.62"	59		46	SHYDC-0720	CSS-1015M	9.17
CV50B-SHYD125-462	1 1/4"	60		4.62"	60		51	HYDC-1020	CSS-1015M	9.57

Boring Bar Blank - Inch

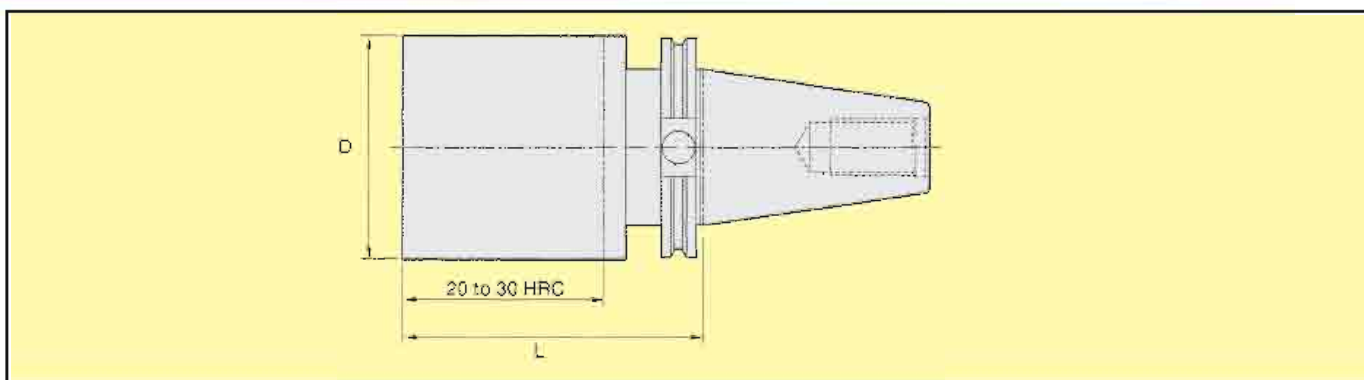

- Balance By Design, Machinable front end 20-30 HRC, 1"- 8 UNC Draw Bar Thread
- Order Example – CV50BB400120

Catalogue No.	D	L	Wt. Lbs
CV50BB400120	4,00"	12,00"	44.56
CV50BB400600	4,00"	6,00"	23.23
CV50BB600600	6,00"	6,00"	43.50

CV 50 Shank Tools

Caterpillar (inch) CV ANSI B5.50 / ISO 7388



Shrink Fit Adapters - Inch

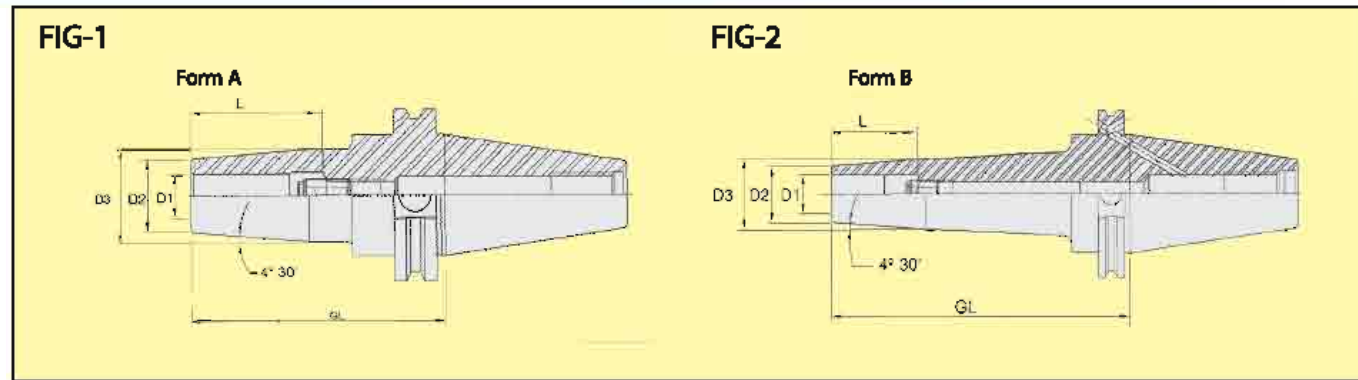

- Pre Balanced G6.3 @ 15,000 rpm,
- Through the tool holder coolant capability, Suitable for carbide & HSS Cutting tool, Runout < 0,003mm (0,0001"), 10mm (3/8") axial adjustment
- Order Example – CV50BSF025350
- Dynamically balanced to G2.5 at 20,000 rpm available on request
- Order Example – CV50BSF025350-G2.5

Available on Form B/AD Shank, Suitable
Order Example – CV50BSF025350

Shrink Fit Adapters – Inch.

Catalogue No.	FIG	D1	D2	D3	GL	L	Wt. Lbs	Stop Screw
CV50BSF025350	1	1/4	0.83	1.06	3.50	1.41	6.83	BTTSS05014M
CV50BSF025600	2	1/4	0.83	1.06	6.00	1.41	8.09	BTTSS05014M
CV50BSF031350	1	5/16	0.83	1.06	3.50	1.41	6.82	BTTSS06014M
CV50BSF031600	2	5/16	0.83	1.06	6.00	1.41	8.08	BTTSS06014M
CV50BSF038375	1	3/8	0.94	1.26	3.75	1.61	7.01	BTTSS08014M
CV50BSF038600	2	3/8	0.94	1.26	6.00	1.61	8.59	BTTSS08014M
CV50BSF044375	1	7/16	0.94	1.26	3.75	1.81	7.02	BTTSS10014M
CV50BSF044600	2	7/16	0.94	1.26	6.00	1.81	8.57	BTTSS10014M
CV50BSF050375	1	1/2	0.94	1.26	3.75	1.81	6.99	BTTSS10014M
CV50BSF050600	2	1/2	0.94	1.26	6.00	1.81	8.54	BTTSS10014M
CV50BSF056375	1	9/16	1.06	1.34	3.75	1.81	7.10	BTTSS10014M
CV50BSF056600	2	9/16	1.06	1.34	6.00	1.85	8.78	BTTSS10014M
CV50BSF062375	1	5/8	1.06	1.34	3.75	1.93	6.00	BTTSS12014M
CV50BSF062600	2	5/8	1.06	1.34	6.00	1.93	8.74	BTTSS12014M
CV50BSF068400	1	11/16	1.30	1.65	4.00	1.93	7.50	BTTSS12014M
CV50BSF068600	2	11/16	1.30	1.65	6.00	1.93	9.89	BTTSS12014M
CV50BSF075400	1	3/4	1.30	1.65	4.00	2.00	7.44	BTTSS16014M
CV50BSF075600	2	3/4	1.30	1.65	6.00	2.00	9.83	BTTSS16014M
CV50BSF088400	1	7/8	1.30	1.65	4.00	2.00	7.35	BTTSS16014M
CV50BSF088600	2	7/8	1.30	1.65	6.00	2.00	9.74	BTTSS16014M
CV50BSF100400	1	1.00	1.73	2.08	4.00	2.40	8.09	BTTSS16014M
CV50BSF100600	2	1.00	1.73	2.08	6.00	2.40	12.00	BTTSS16014M
CV50BSF125400	1	1 1/4	1.73	2.08	4.00	2.40	7.79	BTTSS16014M
CV50BSF125600	2	1 1/4	1.73	2.08	6.00	2.40	11.68	BTTSS16014M

CV 50 Shank Tools

Caterpillar (inch) CV ANSI B5.50 / ISO 7388



Shell Mill Adapters - Inch

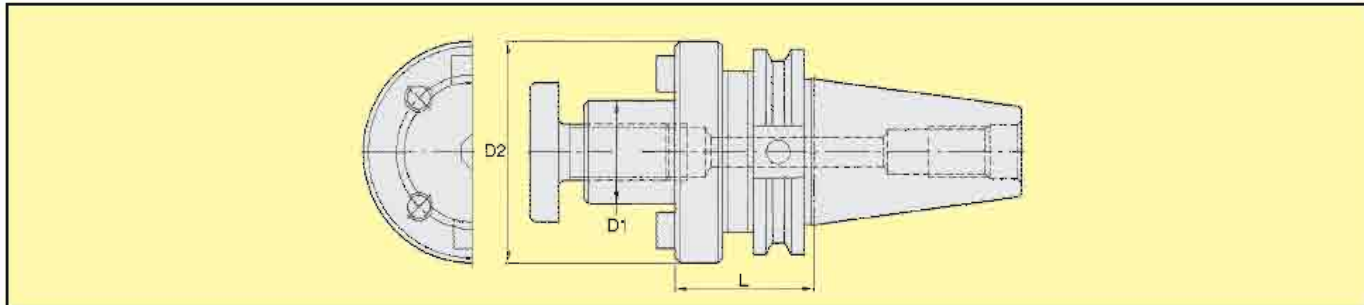

- Balanced by Design, Through the tool holder coolant capability
- Order Example – CV50SM050138

Shell Mill Adapters - Inch

Catalogue No.	D1	D2	L	Wt. Lbs	Lock Screw	Allen Key	Drive Key
CV50SM050138	½	2.75	1.38	6.82	BKLS05	3/16	BKDK04
CV50SM050350	½	1.44	3.50	7.54	BKLS05	3/16	BKDK04
CV50SM075138	¾	2.75	1.38	6.88	BKLS07	¼	BKDK05
CV50SM075350	¾	1.75	3.50	8.34	BKLS07	¼	BKDK05
CV50SM075600	¾	1.75	6.00	9.70	BKLS07	¼	BKDK05
CV50SM100206	1	2.19	2.06	7.37	BKLS10	5/16	BKDK06
CV50SM100400	1	2.40	4.00	9.97	BKLS10	5/16	BKDK06
CV50SM100600	1	2.40	6.00	12.46	BKLS10	5/16	BKDK06
CV50SM125212	1 1/4	2.75	2.12	7.18	BKLS12	5/16	BKDK08
CV50SM125400	1 1/4	2.75	4.00	10.31	BKLS12	5/16	BKDK08
CV50SM150241	1 1/2	3.38	2.41	9.71	BKLS15	3/8	BKDK10
CV50SM150400	1 1/2	3.38	4.00	12.27	BKLS15	3/8	BKDK10

Jacobs Taper Adapters - Inch

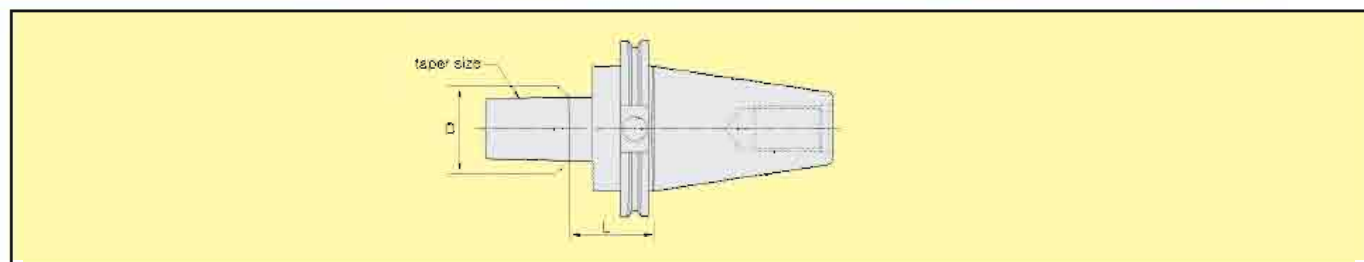

- Balanced by Design, No through-coolant capability. Recommended for tools with a Jacobs internal taper.
- Order Example – CV50JT2244

Catalogue No.	Taper Size	D	L	Wt. Lbs
CV50JT2244	2	0.560	2.440	2.93
CV50JT3278	3	0.812	2.780	3.06
CV50JT33256	33	0.625	2.560	2.96
CV50JT4325	4	1.124	3.25	6.97
CV50JT5325	5	1.413	3.25	7.25
CV50JT6259	6	0.676	2.59	7.3

HSK 63A Shank Tools

DIN 69893 part 1, form A



ER Collet Chucks

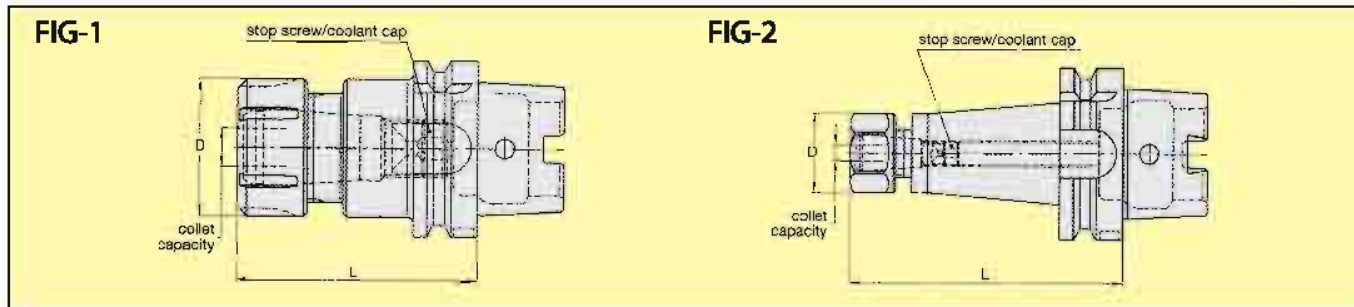

Balanced by Design, Through tool holder coolant capability

Order Example – HSK63AER25100M

Dynamically balanced to G6.3 @ 15,000 rpm & G2.5 at 20,000 rpm, available on request

Order Example – HSK63AER25100M-G2.5

ER Collet Chucks

Catalogue No.	Collet Series	Collet Cap Min.-Max.	Fig	D	L	Wt. Kg.	Locknut	Wrench	Stop Screw
HSK63AER16100M	16ER	0.5 – 10	2	28	100	0.90	LNHER16M	OEW25M	BSS044038G
HSK63AER16160M	16ER	0.5 – 10	2	28	160	1.32	LNHER16M	OEW25M	BSS044038G
HSK63AER20100M	20ER	0.5 – 13	2	34	100	1.03	LNHER20M	OEW30M	BSS056041G
HSK63AER25100M	25ER	1 – 16	1	42	100	1.18	LNER25M	ER25WM	BSS075041G
HSK63AER32100M	32ER	2 – 20	1	50	100	1.37	LNER32M	ER32WM	BSS094041G
HSK63AER40120M	40ER	3 – 26	1	63	120	1.80	LNER40M	ER40WM	BSS112041G

TG Collet Chucks

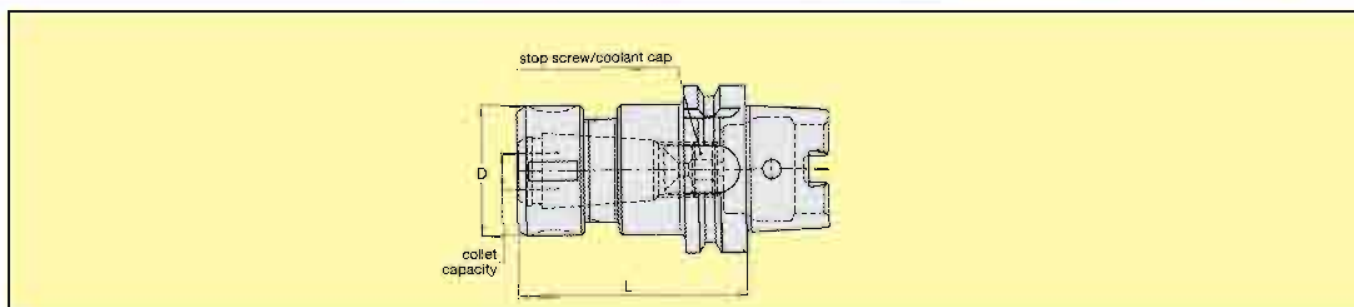

• Tremendous Grip, Balanced by Design, Through tool holder coolant capability

• Order Example – HSK63ATG075115M

• Dynamically balanced to G6.3 @ 15,000 rpm & G2.5 at 20,000 rpm available on request

• Order Example – HSK63ATG075115M-G2.5

TG Collet Chucks

Catalogue No.	Collet Series	Collet Cap Min.-Max.	D	L	Wt. Kg.	Locknut	Wrench	Stop Screw
HSK63ATG075115M	75TG	2.6 – 20.00	50	115	1.65	LNA075M	HSW45M	BSS081041G
HSK63ATG100135M	100TG	2.6 – 25.50	60	135	2.05	LNA100M	HSW58M	BSS112041G

HSK 63A Shank Tools

DIN 69893 part 1, form A



End Mill Adapters - Inch

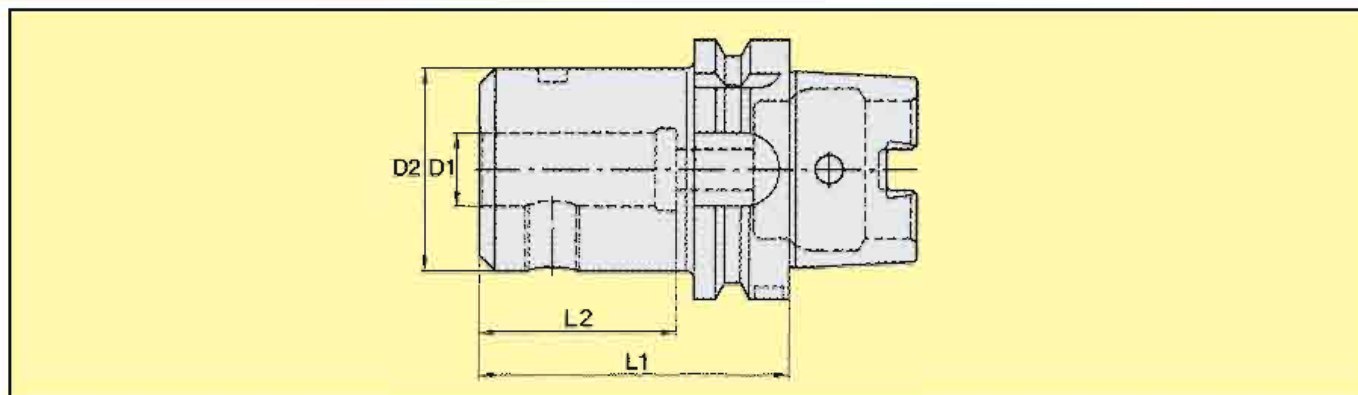

- Balanced by Design, Through the tool holder coolant capability
- Order Example – HSK63AEM025300
- Dynamically balanced to G6.3 @ 15,000 rpm & G2.5 at 20,000 rpm available on request
- Order Example – HSK63AEM025300-G2.5

End Mill Adapters HSK – Inch

Catalogue No.	D1	D2	L1	L2	Wt. Lbs	Clamping Screw	No. of Clamp Screw	Wrench Allen Key
HSK63AEM025300	¼	1.00	3.00	2.14	1.79	BELS025025PKG	1	1/8
HSK63AEM038300	3/8	1.00	3.00	1.73	1.76	BELS038031PKG	1	3/16
HSK63AEM050300	½	1.38	3.00	1.97	2.05	BELS044038PKG	1	7/32
HSK63AEM062375	5/8	1.63	3.75	2.09	2.71	BELS056050PKG	1	¼
HSK63AEM075375	¾	1.75	3.75	2.22	2.85	BELS062050PKG	1	5/16
HSK63AEM100375	1	2.00	3.75	2.46	3.11	BELS075056PKG	2	3/8
HSK63AEM125425	1 ¼	2.50	4.25	2.51	4.51	BELS075062PKG	2	3/8

Drill Chucks

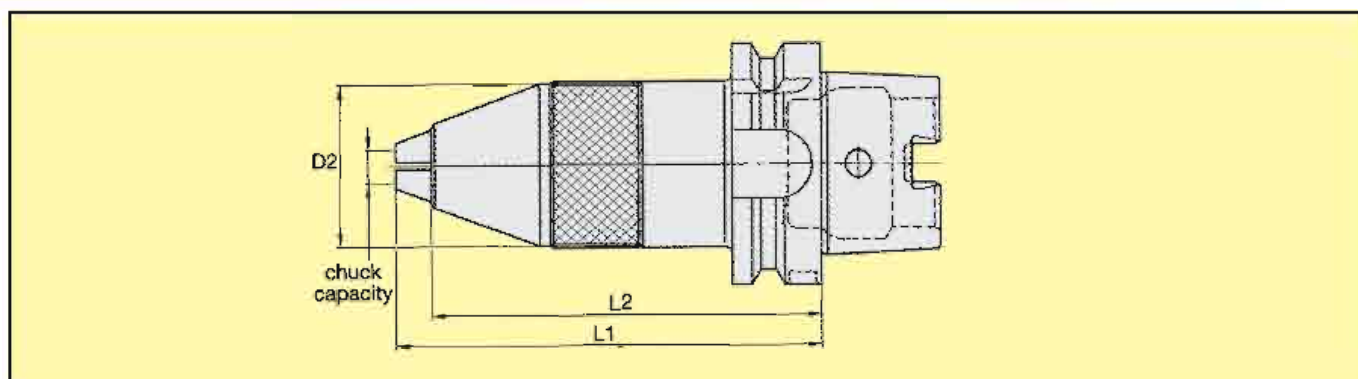

- Recommended for light drilling
- Through the tool holder coolant capability / along cutting tool shank
- Order Example – HSK63ADC13117M

DC-HSK Form-A

Catalogue No.	D1 Min.-Max	D2	L1	L2	Wt. Kg.	Wrench
HSK63ADC13117M	1 - 13	50	126	117	2.00	13S

HSK 63A Shank Tools

DIN 69893 part 1, form A



Morse Taper Adapters

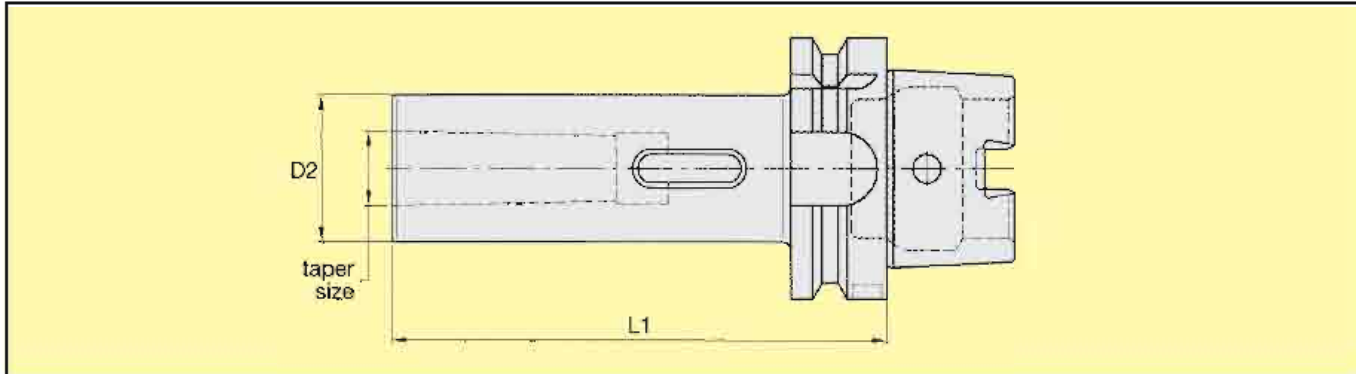

- Balance by Design, No through coolant capability
- Recommended for tools with a morse taper and tang
- Order Example – HSK63AMT1100M

MT – HSK Form-A

Catalogue No.	Taper Size	D2	L1	Wt. Kg.
HSK63AMT1100M	1	25	100	0.72
HSK63AMT2120M	2	32	120	0.94
HSK63AMT3140M	3	40	140	1.29
HSK63AMT4160M	4	48	160	1.72

Boring Bar Blank

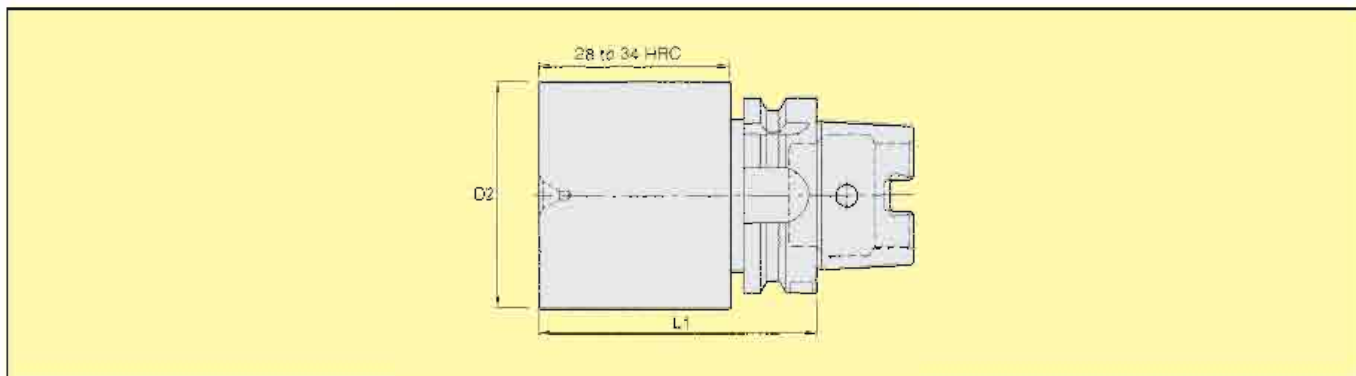

- Machinable front end 28-34 HRC
- Order Example – HSK63ABB080250M

Catalogue No.	D2	L1	Wt. Kg.
HSK63ABB080250M	80.80	250	9.09
HSK63ABB115150M	115.80	150	9.64

HSK 63A Shank Tools

DIN 69893 part 1, form A



Shrink Fit Adapters – Inch

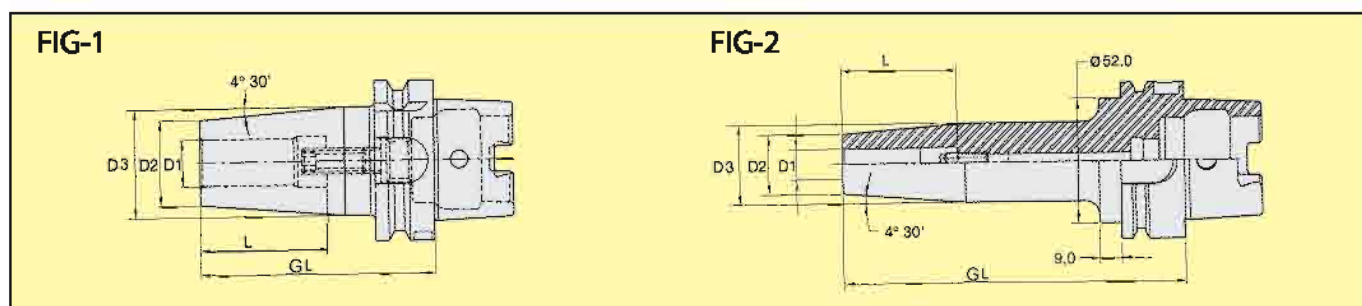

- Pre Balanced G6.3 @ 15,000 rpm, Through tool holder coolant capability, Suitable for carbide & HSS Cutting tool, Run out < 0,003mm (0,0001"), 10mm (3/8") axial adjustment.
- Order Example – HSK63ASF025315
- Dynamically balanced to G2.5 @ 20,000 rpm available on request
- Order Example – HSK63ASF025315-G2.5

SF-HSK Form A - Inch

Catalogue No.	FIG	D1	D2	D3	GL	L	Wt. Lbs	Stop Screw
HSK63ASF025315	1	1/4	0.83	1.06	3.15	1.41	1.83	BTTSS05014M
HSK63ASF025472	1	1/4	0.83	1.06	4.72	1.41	2.44	BTTSS05014M
HSK63ASF025630	2	1/4	0.83	1.06	6.30	1.41	2.92	BTTSS05014M
HSK63ASF031315	1	5/16	0.83	1.06	3.15	1.41	1.82	BTTSS06014M
HSK63ASF031472	1	5/16	0.83	1.06	4.72	1.41	2.40	BTTSS06014M
HSK63ASF031630	2	5/16	0.83	1.06	6.30	1.41	2.91	BTTSS06014M
HSK63ASF038335	1	3/8	0.94	1.26	3.35	1.53	2.00	BTTSS08014M
HSK63ASF038472	1	3/8	0.94	1.26	4.72	1.53	2.66	BTTSS08014M
HSK63ASF038630	2	3/8	0.95	1.26	6.30	1.53	3.30	BTTSS08014M
HSK63ASF044354	1	7/16	0.94	1.26	3.54	1.61	2.03	BTTSS10014M
HSK63ASF044472	1	7/16	0.94	1.26	4.72	1.61	2.63	BTTSS10014M
HSK63ASF044630	2	7/16	0.94	1.26	6.30	1.61	3.30	BTTSS10014M
HSK63ASF050354	1	1/2	0.94	1.26	3.54	1.81	2.01	BTTSS10014M
HSK63ASF050472	1	1/2	0.94	1.26	4.72	1.81	2.61	BTTSS10014M
HSK63ASF050630	2	1/2	0.95	1.26	6.30	1.81	3.25	BTTSS10014M
HSK63ASF056354	1	9/16	1.06	1.34	3.54	1.81	2.13	BTTSS10014M
HSK63ASF056472	1	9/16	1.06	1.34	4.72	1.81	3.61	BTTSS10014M
HSK63ASF056630	2	9/16	1.06	1.34	6.30	1.81	3.30	BTTSS10014M
HSK63ASF062374	1	5/8	1.06	1.34	3.74	1.93	2.15	BTTSS12014M
HSK63ASF062472	1	5/8	1.06	1.34	4.72	1.93	2.72	BTTSS12014M
HSK63ASF062630	2	5/8	1.06	1.34	6.30	1.93	3.46	BTTSS12014M
HSK63ASF068374	1	11/16	1.30	1.65	3.74	1.96	2.15	BTTSS12014M
HSK63ASF068630	2	11/16	1.30	1.65	6.30	1.96	3.46	BTTSS12014M
HSK63ASF075394	1	3/4	1.30	1.65	3.94	2.00	2.60	BTTSS16014M
HSK63ASF075630	2	3/4	1.30	1.65	6.30	2.00	4.21	BTTSS16014M
HSK63ASF088394	1	7/8	1.30	1.65	3.94	2.00	2.51	BTTSS16014M
HSK63ASF088630	2	7/8	1.30	1.65	6.30	2.00	4.12	BTTSS16014M
HSK63ASF100453	1	1	1.73	2.08	4.53	2.21	3.88	BTTSS16014M
HSK63ASF100630	2	1	1.73	2.08	6.30	2.21	5.53	BTTSS16014M
HSK63ASF125472	1	1 1/4	1.73	2.08	4.72	2.40	3.73	BTTSS16014M
HSK63ASF125630	2	1 1/4	1.73	2.08	6.30	2.40	5.20	BTTSS16014M

HSK 63A Shank Tools

DIN 69893 part 1, form A



Shell Mill Adapters - Inch

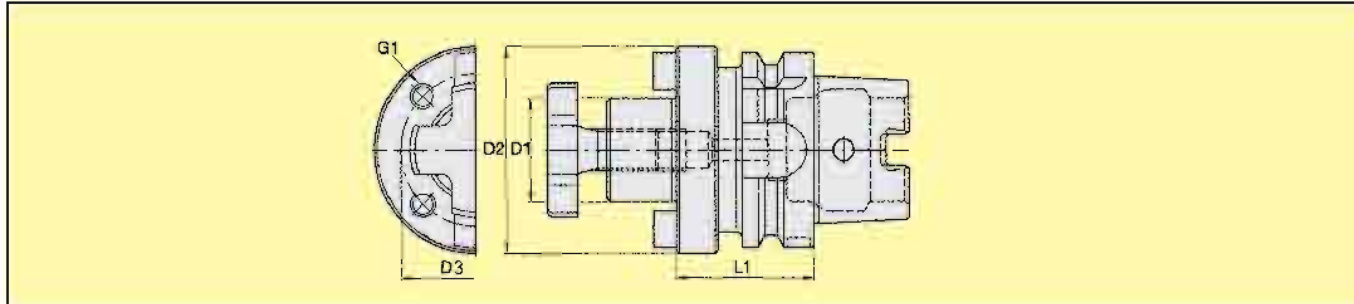

- Balanced by Design, Through the tool holder coolant capability
- Order Example – HSK63ASM050200

Shell Mill Adapters – Inch

Catalogue No.	D1	D2	D3	L	G1	Wt. Lbs	Lock Screw	Wrench	Drive Key
HSK63ASM050200	1/2	1.75	NA	2.00	NA	2.11	BKLS05	3/16	BKDK04
HSK63ASM075200	3/4	1.75	NA	2.00	NA	2.18	BKLS07	1/4	BKDK05
HSK63ASM100225	1.00	2.19	NA	2.25	NA	2.87	BKLS10	5/16	BKDK06
HSK63ASM125225	1 1/4	2.88	NA	2.25	NA	3.68	BKLS12	5/16	BKDK08
HSK63ASM150225	1 1/2	3.81	NA	2.25	NA	4.49	BKLS15	3/8	BKDK10

Slitting Cutter Adapters – Inch

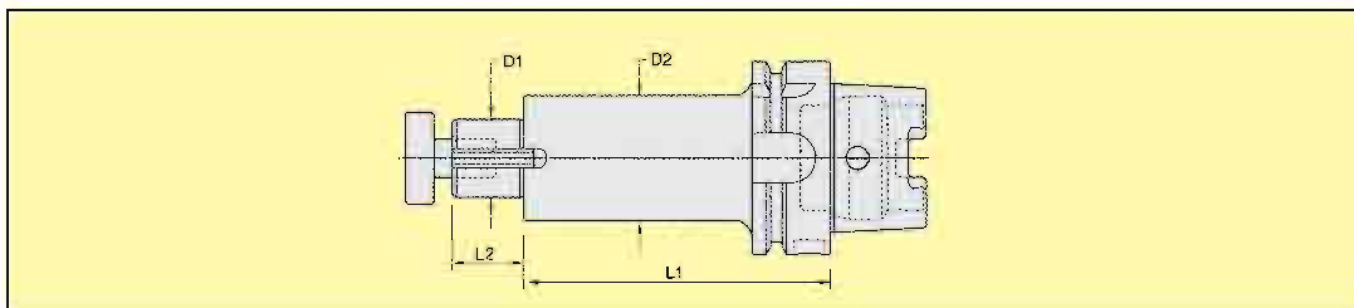

- Balanced by Design
- Order Example – HSK63ASA062400

Catalogue No.	D1	D2	L 1	L 2	Wt. Lbs	Lock Screw	Wrench	Drive Key
HSK63ASA062400	5/8	1.25	4.00	0.78	2.22	BKLS07	1/4	BSDK062088
HSK63ASA100400	1	1.61	4.00	0.95	3.09	BKLS10	5/16	BSDK100106
HSK63ASA125400	1 1/4	1.86	4.00	1.09	3.97	BKLS12	5/16	BSDK125119

Straight Shank Tools

ER Collets Chucks On Straight Shank - Inch

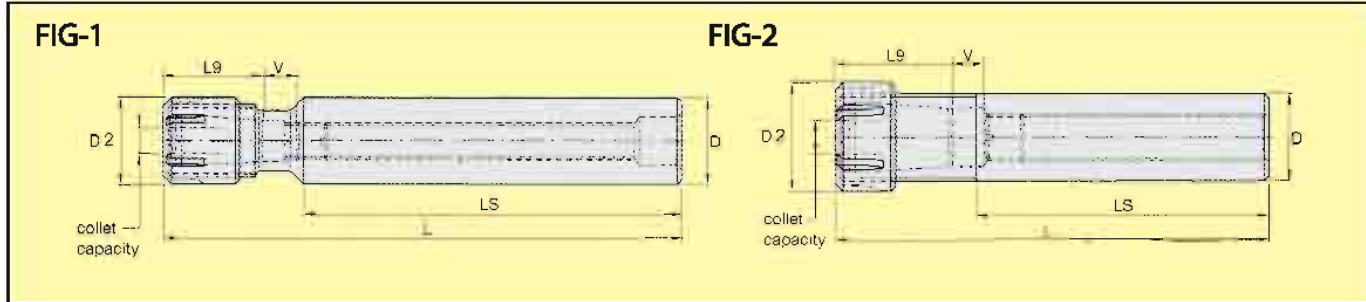

- Through the tool holder coolant capability
- Order Example – SS050ER11700

ER-SS – Inch

Catalogue No.	Collet Series	Collet Cap Min.-Max.	Fig	D	D2	L	LS	L9	V	Wt. Lbs	Locknut	Wrench	Stop Screw
SS050ER11700	11ER	0.020-0.276	1	0.50	0.63	7.00	5.51	1.27	5.04	0.40	LNER11M	ER11WEM	BSS031031G
SS075ER16700	16ER	0.020-0.406	1	0.75	0.87	7.00	5.51	1.24	2.30	0.90	LNER16M	ER16WEM	BSS044038G
SS100ER20700	20ER	0.020-0.512	2	1.00	1.38	7.00	5.51	1.42	4.89	1.60	LNHER20M	OEW30M	BSS056041G
SS100ER25750	25ER	0.040-0.630	2	1.00	1.65	7.50	5.69	1.57	5.24	1.70	LNHER25M	ER25WM	BSS075041G

DA Collet Chucks On Straight Shank - Inch

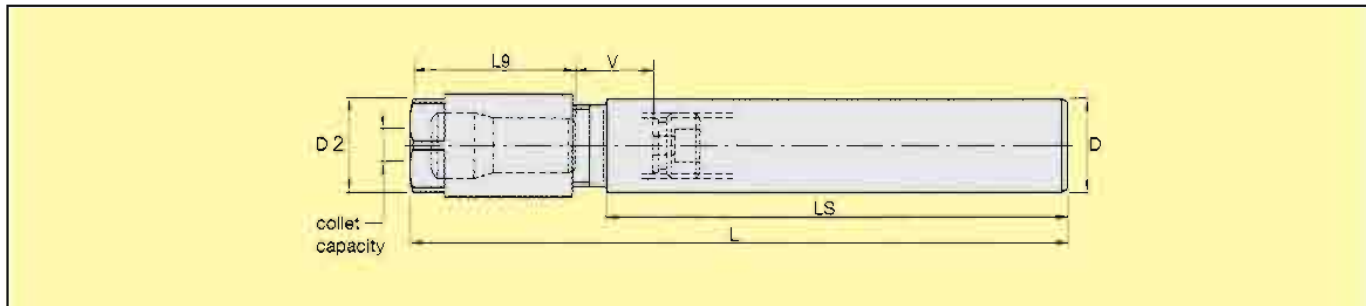

- Through the tool holder coolant capability, Small outside diameter is ideal for use with machining centers & solving close center distance & fixture clearance problems.
- Order Example – SS050DA304681

DA Style 04-SS - Inch

Catalogue No.	Collet Series	Collet Cap Min.-Max.	D	D2	L	LS	L9	V	Wt. Lbs	Locknut	Wrench	Stop Screw
SS050DA304681	300DA	1/64-1/4	0.50	0.56	6.81	5.42	1.50	2.75	0.37	LNA304M	OEW050	BSS031031G
SS075DA204712	200DA	1/64-25/64	0.75	0.84	7.12	5.50	1.56	3.19	0.89	LNA204M	OEW075	BSS044038G
SS100DA104731	100DA	1/64-9/16	1.00	1.06	7.31	5.40	1.94	4.68	1.62	LNA104M	OEW094	BSS062041G
SS125DA184738	180DA	1/64-3/4	1.25	1.44	7.38	5.41	1.88	4.74	2.56	LNA184M	OEW119	BSS081041G

R8-Shank End Mill Adapters

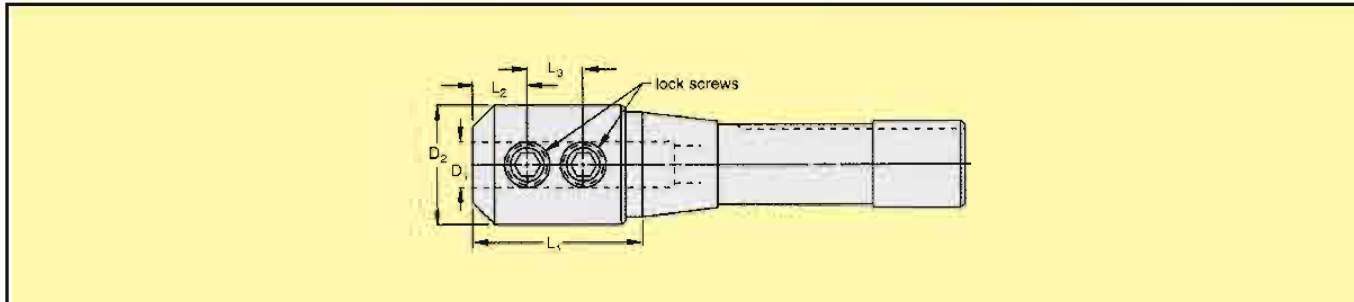

Order Example-R8EM018112
 • Supplied with Lock Screws
 • Knurled nose for added safety

Catalogue No.	Tool Capacity D1	Body Diameter D2	Projection Length L1	L2	L3	Lock Screw	Weight in Lbs.
R8EM018112	3/16"	0.94"	1.12"	0.406"		¼-28 UNF	0.9
R8EM038100	3/8"	1.25"	1.00"	0.719"		3/8-24 UNF	1.1
R8EM050112	½"	1.25"	1.12"	0.875"		7/16-20 UNF	1.2
R8EM062150	5/8"	1.58"	1.50"	0.875"		½-20 UNF	2.1
R8EM075262	¾"	1.72"	2.62"	1.109"		5/8-18 UNF	4.0
R8EM088306	7/8"	1.94"	3.06"	1.063"	0.828"	¾-16 UNF	5.2
R8EM100306	1"	1.94"	3.06"	1.109"	0.953"	¾-16 UNF	5.2
R8EM125306	1 ¼"	2.38"	3.06"	1.109"	0.953"	¾-16UNF	6.4

R8-Shank Shell Mill Adapters

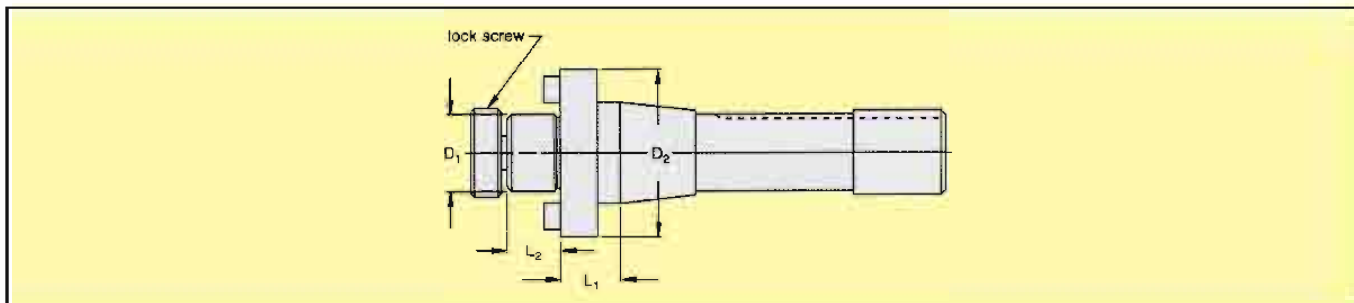

Order Example-R8EM018112
 • Supplied with Lock Screw & Drive Key

Shell Mill Adapters - Inch

Catalogue No.	Pilot Capacity D1	Projection Diameter D2	Projection Length L1	Pilot Length L2	Lock Screw	Weight in Lbs
R8SM050102	½"	1.28"	1.02"	0.562"	KLS05	1.4"
R8SM075102	¾"	1.62"	1.02"	1.671"	KLS07	1.8"
R8SM100102	1.00"	1.97"	1.02"	0.671"	KLS10	2.3"
R8SM125102	1.25"	2.50"	1.02"	0.671"	KLS12	3.0"
R8SM150175	1.50"	2.95"	1.75"	0.938"	KLS15	5.8"

ER-Collet

DIN 6499 Class II



ER Series Collets – Inch

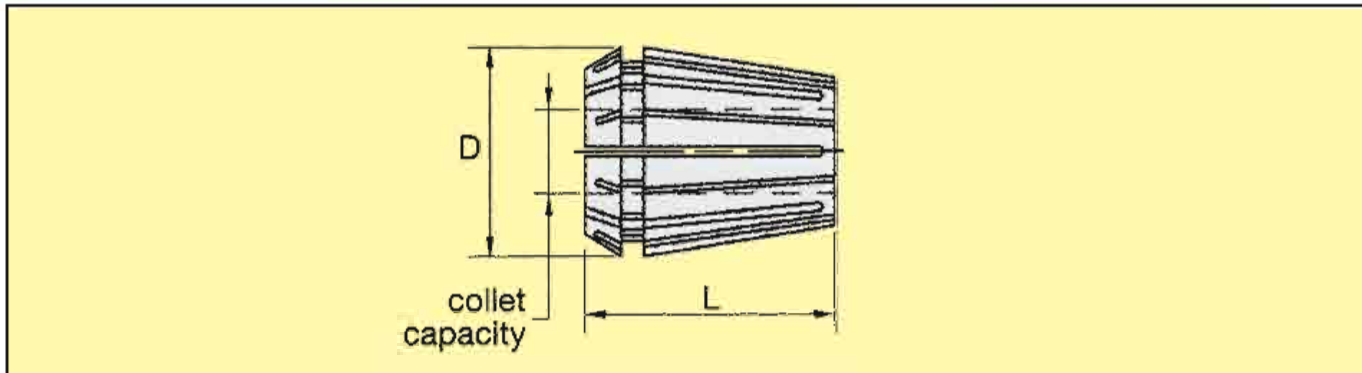

- Manufactured to DIN 6499, Accuracy to-DIN 6499 Class II, Wide clamping range, Max.Collapse =0.04"
Order Example – 16ER0062

Bonded Collets are available on request.
Lock Nuts to be ordered separately along with Bonded Collets, Max.Collapse =0.005", Suitable for Coolant pressure upto-1000psi
Order Example – 16ER0062B

Fraction	Collet Capacity	ER-16 D=0.669" L=1.083	ER-20 D=0.827" L=1.240	ER-25 D=1.024" L=1.339	ER-32 D=1.299" L=1.575	ER-40 D=1.614" L=1.811
1/16	0.0625-0.0225					
3/32	0.0938-0.0538		20ER0094			
1/8	0.1250-0.0850					
5/32	0.1563-0.1163		20ER0156		32ER0156	
3/16	0.1875-0.1475	16ER0188	20ER0188	25ER0188	32ER0188	40ER0188
7/32	0.2188-0.1788	16ER0219			32ER0219	
¼	0.2500-0.2100	16ER0250	20ER0250	25ER0250	32ER0250	40ER0250
9/32	0.2813-0.2413	16ER0281			32ER0281	
5/16	0.3125-0.2725	16ER0312	20ER0312	25ER0312	32ER0312	40ER0312
11/32	0.3438-0.3038	16ER0344			32ER0344	40ER0344
3/8	0.3750-0.3350	16ER0375	20ER0375	25ER0375	32ER0375	40ER0375
13/32	0.4063-0.3663	16ER0406			32ER0406	
7/16	0.4375-0.3975		20ER0438	25ER0438	32ER0438	40ER0438
15/32	0.4688-0.4288				32ER0469	
½	0.5000-0.4600		20ER0500	25ER0500	32ER0500	40ER0500
17/32	0.5313-0.4913				32ER0531	40ER0531
9/16	0.5625-0.5225			25ER0562	32ER0562	40ER0562
19/32	0.5938-0.5538				32ER0594	
5/8	0.6250-0.5850			25ER0625	32ER0625	40ER0625
21/32	0.6563-0.6163					
11/16	0.6875-0.6475				32ER0688	40ER0688
23/32	0.7188-0.6788					
¾	0.7500-0.7100				32ER0750	40ER0750
25/32	0.7813-0.7413					
13/16	0.8125-0.7725					
27/32	0.8438-0.8038					
7/8	0.8750-0.8350					40ER0875
29/32	0.9063-0.8663					
15/16	0.9375-0.8975					40ER0938
31/32	0.9688-0.9288					
1	1.0000-0.9600					40ER1000

ER-Collet

DIN 6499 Class II



ER Series Collets – Metric

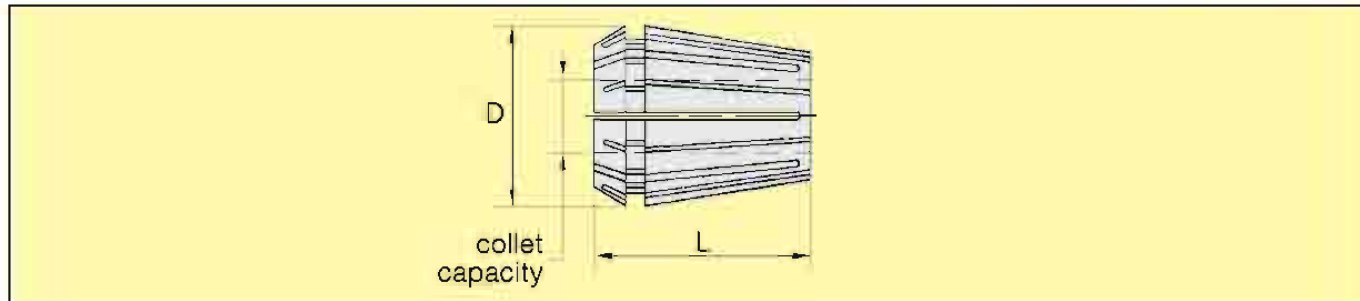

Manufactured to DIN 6499, Accuracy to-DIN 6499 Class II, Wide clamping range, Max.Collapse =1mm

Order Example – 16ER010M

Bonded Collets are available on request. Lock Nuts to be ordered separately along with Bonded Collets, Max.Collapse =0.13mm,

Suitable for Coolant pressure upto-70 bar.

Order Example – 16ER010MB

Collet Capacity Max - Min	ER-16 D=17 L=27.5 Catalogue No.	ER-20 D=21 L=31.5 Catalogue No.	ER-25 D=26 L=34 Catalogue No.	ER-32 D=33 L=40 Catalogue No.	ER-40 D=41 L= 46 Catalogue No.
1.0 – 0.5	16ER010M	20ER010M			
1.5 – 1.0	16ER015M				
2.0 – 1.0	16ER020M	20ER020M	25ER020M		
2.5 – 1.5	16ER025M				
3.0 – 2.0	16ER030M	20ER030M	25ER030M	32ER030M	
3.5 – 2.5	16ER035M				
4.0 – 3.0	16ER040M	20ER040M	25ER040M	32ER040M	40ER040M
4.5 – 3.5	16ER045M				
5.0 – 4.0	16ER050M	20ER050M	25ER050M	32ER050M	40ER050M
5.5 – 4.5	16ER055M				
6.0 – 5.0	16ER060M	20ER060M	25ER060M	32ER060M	40ER060M
6.5 – 5.5	16ER065M				
7.0 – 6.0	16ER070M	20ER070M	25ER070M	32ER070M	40ER070M
7.5 – 6.5	16ER075M				
8.0 – 7.0	16ER080M	20ER080M	25ER080M	32ER080M	40ER080M
8.5 – 7.5	16ER085M				
9.0 – 8.0	16ER090M	20ER090M	25ER090M	32ER090M	40ER090M
9.5 – 8.5	16ER095M				
10.0 – 9.0	16ER100M	20ER100M	25ER100M	32ER100M	40ER100M
11.0 – 10.0		20ER110M	25ER110M	32ER110M	40ER110M
12.0 – 11.0		20ER120M	25ER120M	32ER120M	40ER120M
13.0 – 12.0		20ER130M	25ER130M	32ER130M	40ER130M
14.0 – 13.0			25ER140M	32ER140M	40ER140M
15.0 – 14.0			25ER150M	32ER150M	40ER150M
16.0 – 15.0			25ER160M	32ER160M	40ER160M
17.0 – 16.0				32ER170M	40ER170M
18.0 – 17.0				32ER180M	40ER180M
19.0 – 18.0				32ER190M	40ER190M
20.0 – 19.0				32ER200M	40ER200M
21.0 – 20.0					40ER210M
22.0 – 21.0					40ER220M
23.0 – 22.0					40ER230M
24.0 – 23.0					40ER240M
25.0 – 24.0					40ER250M
26.0 – 25.0					40ER260M

ER-Collet

DIN 6499 Class II



ER Series Collets – Metric Set / Inch Set

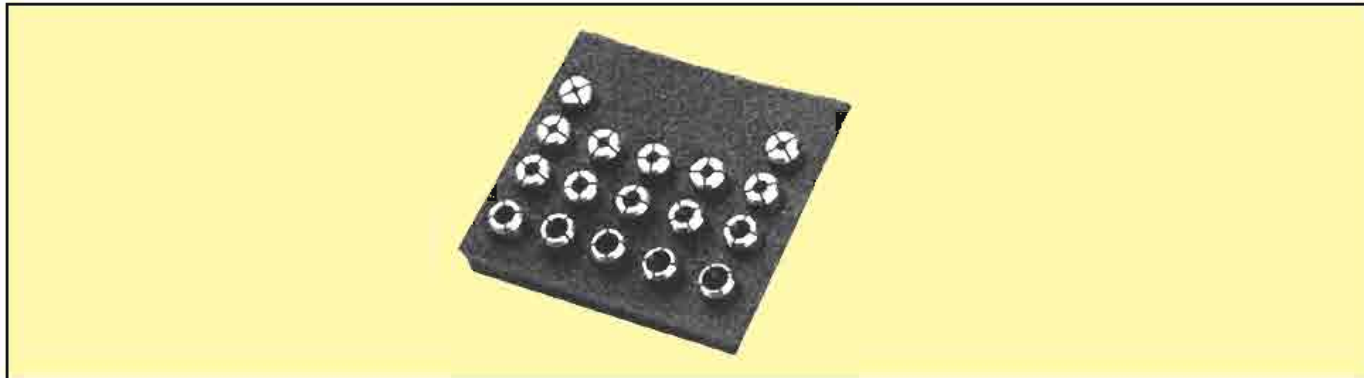

- Manufactured to DIN 6499, Accuracy to-
DIN 6499 Class II, Wide clamping range,
Max.Collapse =1mm
- Order Example – 16ERS000M

CATALOGUE NO.	1-WOODEN TRAY CONSIST OF NO.-PIECES FROM – TO DIA INCREMENTS
16ERS000M	10-Pieces 1.00mm to 10.00mm 1.00mm Increments
20ERS000M	12-Pieces 2.00mm to 13.00mm 1.00mm Increments
25ERS000M	15-Pieces 2.00mm to 16.00mm 1.00mm Increments
32ERS000M	18-Pieces 3.00mm to 20.00mm 1.00mm Increments
40ERS000M	23-Pieces 4.00mm to 26mm 1.00mm Increments

- Manufactured to DIN 6499, Accuracy to-
DIN 6499 Class II, Wide clamping range,
Max.Collapse =0.04"
- Order Example – 16ERS000SET2

CATALOGUE NO.	1-WOODEN TRAY CONSIST OF NO.-PIECES FROM – TO DIA INCREMENTS
16ERS000SET2	12-Pieces 1/16"-13/32" 1/32" Increments
20ERS000SET1	8-Pieces 1/16"-1/2" 1/16" Increments
25ERS000SET1	10-Pieces 1/16"-5/8" 1/16" Increments
32ERS000SET1	12-Pieces 1/8"-13/16" 1/16" Increments
40ERS000SET1	15-Pieces 1/8"-1" 1/16" Increments

TG75 Series Collets – Inch

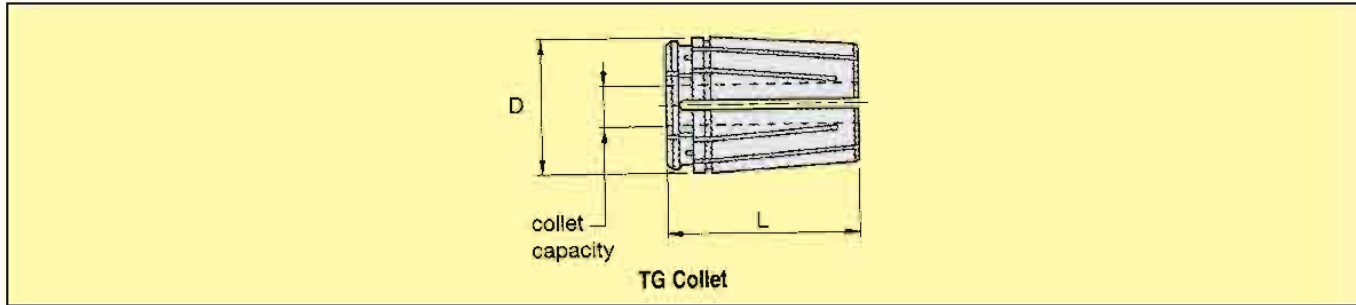

- Provides tremendous Grip and accuracy for all drilling applications. Manufactured to DIN 6499 Class 2 accuracy. Grips on back taper and Margin max feed rate and more accurate hole. Max Collapse 0.016"
- Order Example – 75TG0062

Bonded collets available on request
 Rubber filled slots seal collets for coolant fed tool application. Suitable for Coolant Pressure up to of drill for 1500psi. Fits all standard TG-style collet chucks.
 Max collapse 0.005"
 Order Example – 75TGC0250

Collet Capacity Max - Min	75TG Standard D = 1.062 L = 1.844 Catalogue No.
1/16	75TG0062
5/64	75TG0078
3/32	75TG0094
7/64	75TG0109
1/8	75TG0125
9/64	75TG0141
5/32	75TG0156
11/64	75TG0172
3/16	75TG0188
13/64	75TG0203
7/32	75TG0219
15/64	75TG0234
1/4	75TG0250
17/64	75TG0266
9/32	75TG0281
19/64	75TG0297
5/16	75TG0312
21/64	75TG0328
11/32	75TG0344
23/64	75TG0359
3/8	75TG0375
25/64	75TG039
13/32	75TG0406

Collet Capacity Max - Min	75TG Standard D = 1.062 L = 1.844 Catalogue No.
27/64	75TG0422
7/16	75TG0438
29/64	75TG0453
15/32	75TG0469
31/64	75TG0484
1/2	75TG0500
33/64	75TG0516
17/32	75TG0531
35/64	75TG0547
9/16	75TG0562
37/64	75TG0578
19/32	75TG0594
39/64	75TG0609
5/8	75TG0625
41/64	75TG0641
21/32	75TG0656
43/64	75TG0672
11/16	75TG0688
45/64	75TG0703
23/32	75TG0719
47/64	75TG0734
3/4	75TG0750

TG100 Series Collets – Inch

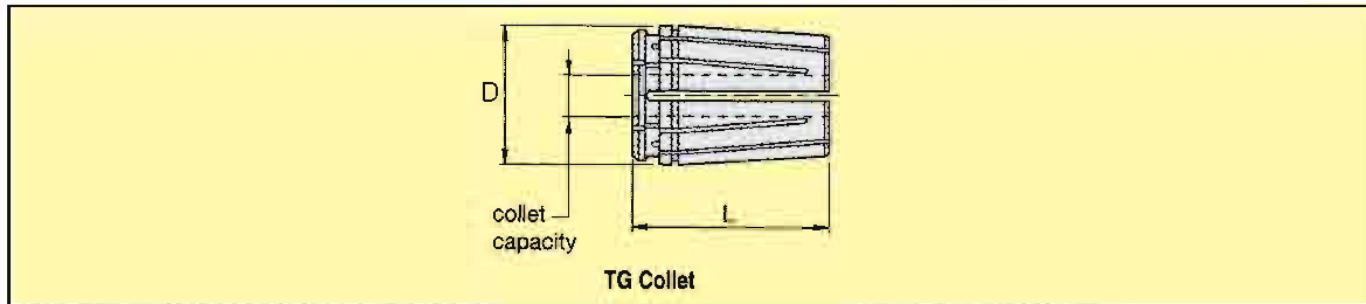

- Provides tremendous Grip and accuracy for all drilling applications. Manufactured to DIN 6499 Class 2 accuracy. Grips on back taper and Margin of drill for max feed rate and more accurate hole. Max Collapse 0.016"
- Order Example – 100TG0094

Bonded collets available on request. Rubber filled slots seal collets for coolant fed tool application. Suitable for Coolant Pressure up to 1500psi. Fits all standard TG-style collet chucks.

Max collapse 0.005"

Order Example – 100TGC0250

Collet Capacity Max - Min	100TG Standard D = 1.379 L = 2.375 Catalogue No.
3/32	100TG0094
7/64	100TG0109
1/8	100TG0125
9/64	100TG0141
5/32	100TG0156
11/64	100TG0172
3/16	100TG0188
13/64	100TG0203
7/32	100TG0219
15/64	100TG0234
1/4	100TG0250
17/64	100TG0266
9/32	100TG0281
19/64	100TG0297
5/16	100TG0312
21/64	100TG0328
11/32	100TG0344
23/64	100TG0359
3/8	100TG0375
25/64	100TG0391
13/32	100TG0406
27/64	100TG0422

Collet Capacity Max - Min	100TG Standard D = 1.379 L = 2.375 Catalogue No.
7/16	100TG0438
29/64	100TG0453
15/32	100TG0469
31/64	100TG0484
1/2	100TG0500
33/64	100TG0516
17/32	100TG0531
35/64	100TG0547
9/16	100TG0562
5/8	100TG0625
21/32	100TG0656
43/64	100TG0672
11/16	100TG0688
3/4	100TG0750
51/64	100TG0797
13/16	100TG0812
7/8	100TG0875
57/64	100TG0891
29/32	100TG0906
61/64	100TG0953
1	100TG1000

TG150 Series Collets – Inch

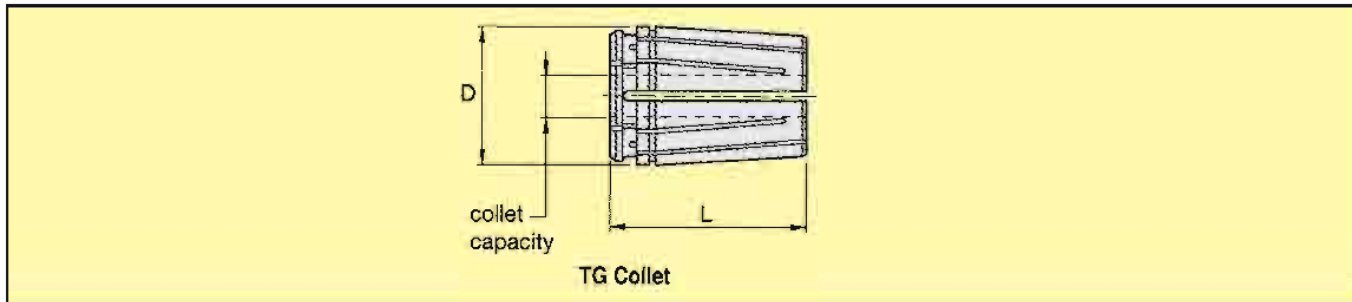

- Provides tremendous Grip and accuracy for all drilling applications. Manufactured to DIN 6499 Class 2 accuracy. Grips on back taper and Margin of drill for max feed rate and more accurate hole. Max Collapse 0.016".
- Order Example – 150TG0375

Collet Capacity	150TG Standard D = 2.00 L = 3.00 Catalogue No.
15/32	150TG0469
1/2	150TG0500
17/32	150TG0531
9/16	150TG0562
37/64	150TG0578
19/32	150TG0594
39/64	150TG0609
5/8	150TG0625
21/32	150TG0656
11/16	150TG0688
45/64	150TG0703
23/32	150TG0719
47/64	150TG0734
3/4	150TG0750
49/64	150TG0766
25/32	150TG0781
51/64	150TG0797
13/16	150TG0812
53/64	150TG0828
27/32	150TG0844
7/8	150TG0875
57/64	150TG0891
29/32	150TG0906
59/64	150TG0922
15/16	150TG0938
61/64	150TG0953

Collet Capacity Max - Min	150TG Standard D = 2.000 L = 3.000 Catalogue No.
31/32	150TG0969
1	150TG1000
1 1/64	150TG1016
1 1/32	150TG1031
1 3/64	150TG1047
1 1/16	150TG1062
1 5/64	150TG1078
1 11/64	150TG1172
1 3/16	150TG1187
1 7/32	150TG1219
1 15/64	150TG1234
1 1/4	150TG1250
1 17/64	150TG1266
1 9/32	150TG1281
1 19/64	150TG1297
1 5/16	150TG1312
1 21/64	150TG1328
1 11/32	150TG1344
1 23/64	150TG1359
1 3/8	150TG1375
1 13/32	150TG1406
1 27/64	150TG1422
1 7/16	150TG1438
1 15/32	150TG1469
1 31/64	150TG1484
1 1/2	150TG1500

DA-COLLET



DA Double Angle Series Collets – Inch

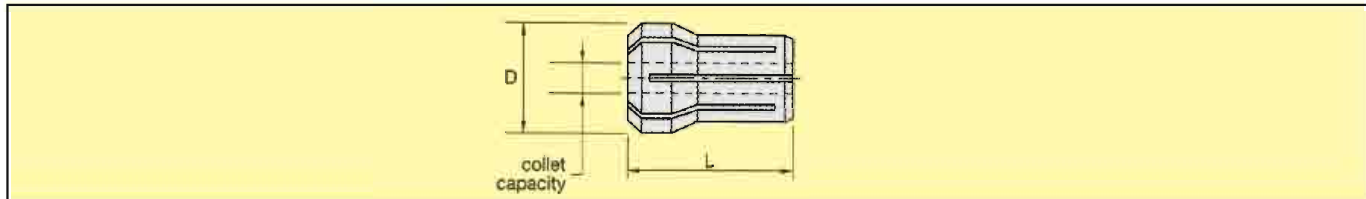

- 300DA / 200DA / 100DA / & 180DA – Standard Collets, Max.collapse= 0.031"
- Order Example – 300DA0031

300DA/200DA / 100DA / & 180DA – Coolant Bonded Collets. available on request, fits all standard DA-style collet chucks, suitable for coolant pressure up to 1000psi, Max.collapse= 0.13mm
Order Example – 300DA0250

Collet Capacity	300DA Standard D= 0.375" L= 1.000"	200DA Standard D= 0.539" L= 1.188"	100DA Standard D = 0.769" L = 1.438"	180DA Standard Met D = 1.035" L = 1.625"
1/32	300DA0031			
3/64	300DA0047			180DA0047
1/16	300DA0062	200DA0062	100DA0062	180DA0062
5/64	300DA0078	200DA0078	100DA0078	180DA0078
3/32	300DA0094	200DA0094	100DA0094	180DA0094
7/64	300DA0109	200DA0109	100DA0109	180DA0109
1/8	300DA0125	200DA0125	100DA0125	180DA0125
9/64	300DA0141	200DA0141	100DA0141	180DA0141
5/32	300DA0156	200DA0156	100DA0156	180DA0156
11/64	300DA0172	200DA0172	100DA0172	180DA0172
3/16	300DA0188	200DA0188	100DA0188	180DA0188
13/64	300DA0203	200DA0203	100DA0203	180DA0203
7/32	300DA0219	200DA0219	100DA0219	180DA0219
15/64	300DA0234	200DA0234	100DA0234	180DA0234
1/4	300DA0250	200DA0250	100DA0250	180DA0250
17/64		200DA0266		180DA0266
9/32		200DA0281	100DA0281	180DA0281
19/64		200DA0297	100DA0297	180DA0297
5/16		200DA0312	100DA0312	180DA0312
21/64		200DA0328		180DA0328
11/32		200DA0344		180DA0344
23/64		200DA0359		180DA0359
3/8		200DA0375	100DA0375	180DA0375
25/64		200DA0391		180DA0391
13/32			100DA0406	180DA0406
27/64			100DA0422	180DA0422
7/16			100DA0438	180DA0438
29/64				180DA0453
15/32			100DA0469	180DA0469
31/64				180DA0484
1/2			100DA0500	180DA0500
33/64				180DA0516
17/32				180DA0531
35/64				180DA0547
9/16			100DA0562	180DA0562
37/64				180DA0578
19/32				180DA0594
39/64				180DA0609
5/8				180DA0625
41/64				
21/32				180DA0656
43/64				
11/16				180DA0688
45/64				
23/32				
47/64				
3/4				180DA0750

Hydraulic Chuck Reduction Sleeve



Reduction Sleeve – Inch

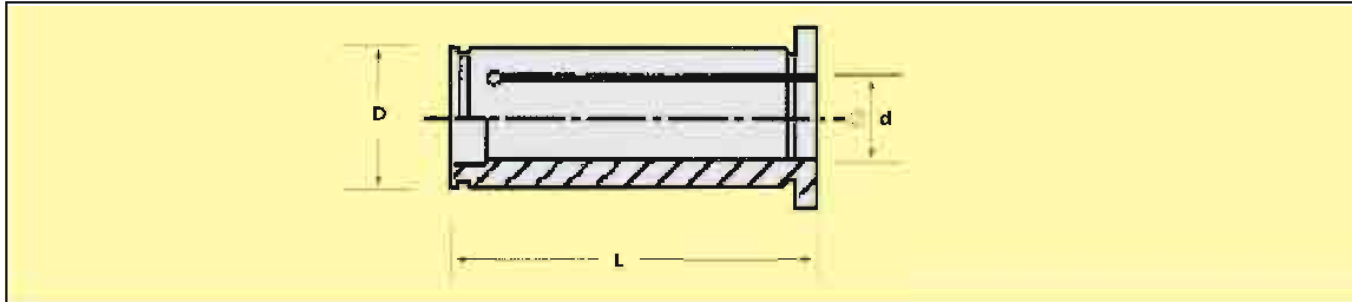

- Reduction Hydraulic Chuck Sleeve Inch.
- `Order Example – 050HC-0125
- Reduction Hydraulic Chuck Sleeve in Metric bore sizes available on request

Catalogue No.	For Hydraulic Chuck Bore Dia.	D	d	L
050HC-0125	1/2"	1/2"	1/8"	1.732"
050HC-0188			3/16"	
050HC-0250			1/4"	
050HC-0312			5/16"	
050HC-0375			3/8"	
075HC-0125	3/4"	3/4"	1/8"	2.126"
075HC-0188			3/16"	
075HC-0250			1/4"	
075HC-0312			5/16"	
075HC-0375			3/8"	
075HC-0438			7/16"	
075HC-0500			1/2"	
075HC-0562			9/16"	
075HC-0625			5/8"	
125HC-0500			1 1/4"	
125HC-0562	9/16"			
125HC-0625	5/8"			
125HC-0688	11/16"			
125HC-0750	3/4"			
125HC-0812	13/16"			
125HC-0875	7/8"			
125HC-1000	1"			

R8-Collets



R8 Collets - Inch

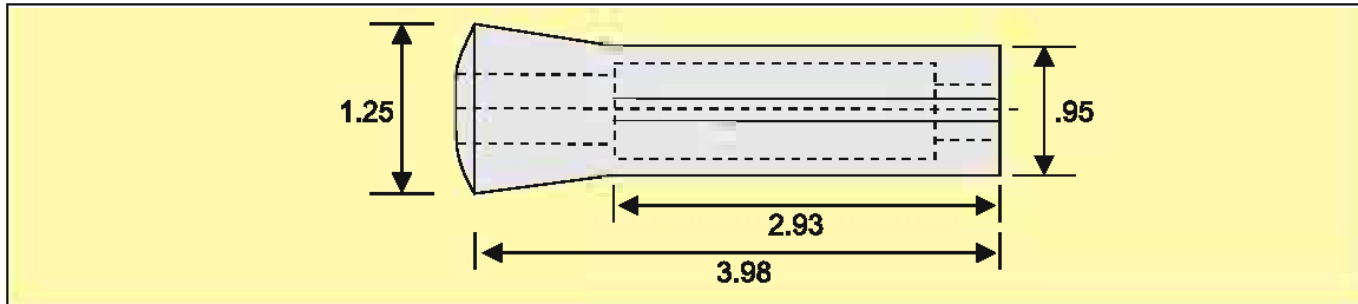

- Order Example-CLT-R80062
- Precision grade R8 Collets
- Hardened and ground
- Inch or Metric Collets sizes
- Reduces tool change time
- High grade steel for long wear life
- Can be used with most R8 Collets Fixtures
- Kits available

Catalogue No.	R8-Collets Size ID	Catalogue No.	R8-Collets Size ID
CLT-R80062	1/16"	CLT-R80438	7/16"
CLT-R80094	3/32"	CLT-R80469	15/32"
CLT-R80125	1/8"	CLT-R80500	1/2"
CLT-R80156	5/32"	CLT-R80531	17/32"
CLT-R80188	3/16"	CLT-R80562	9/16"
CLT-R80219	7/32"	CLT-R80594	19/32"
CLT-R80250	1/4"	CLT-R80625	5/8"
CLT-R80281	9/32"	CLT-R80656	21/32"
CLT-R80312	5/16"	CLT-R80688	11/16"
CLT-R80344	11/32"	CLT-R80734	23/32"
CLT-R80375	3/8"	CLT-R80750	3/4"
CLT-R80406	13/32"	CLT-R80875	7/8"

Tightening Fixtures

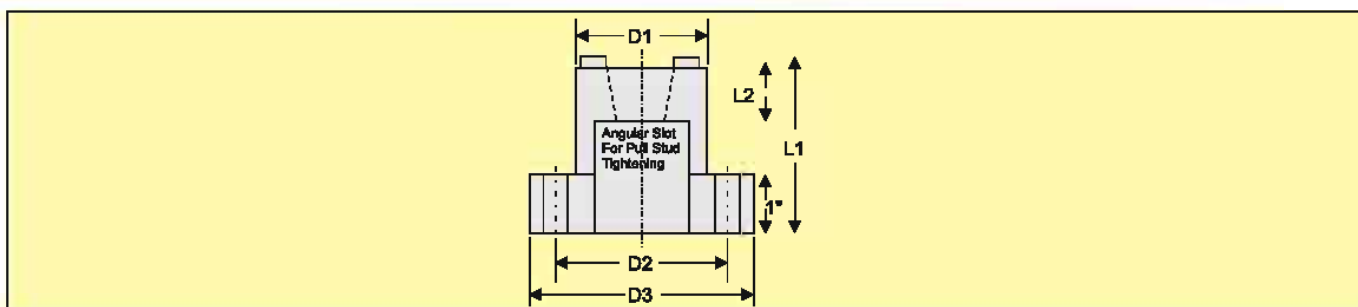

Catalogue No.	D1	D2 PCD	D3 Flange D	Flange Thickness	L1 Total Ht.	L2
TF30	3.5"	4.25"	5.00"	1"	4.5"	1.55"
TF40	3.5"	4.25"	5.00"	1"	5.5"	2.15"
TF50	5.25"	6.00"	6.75"	1"	7.5"	3.50"

Pull Studs – Retention Knobs



Pull Studs RK BT-MAS-403

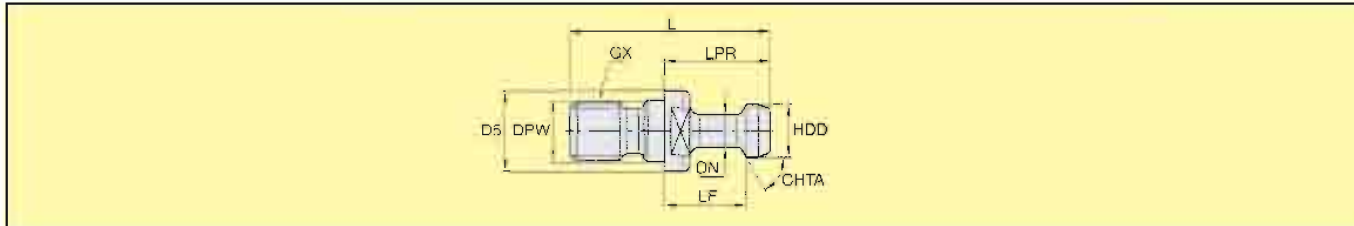

- Pull Studs BT MAS Style With Pilot – Metric
Metric Threads, Piloted, No Through Coolant
- Order Example – RK30BT1M
Through coolant pull studs available upon request
- Order Example – RK30BT1MC

- Pull Studs BT MAS Style With Pilot – Inch
Threads, Piloted, No Through Coolant
- Order Example – RK31114
Through coolant pull studs available upon request
- Order Example – RK31114C

Pull Studs RK BT-MAS-403-METRIC

Catalogue No.	Taper Size	GX	CHTA in Deg.	D5	DN	DPW	HDD	LF	LPR	L	WF
RK30BT1M	30	M12~1.75	45	16.40	6.95	12.49	10.95	17.95	22.95	43	13
RK30BT2M	30	M12~1.75	60	16.40	6.95	12.49	10.95	17.95	22.95	43	13
RK40BT1M	40	M16~2.00	45	22.90	9.95	16.99	14.95	27.95	34.95	60	19
RK40BT2M	40	M16~2.00	60	22.90	9.95	16.99	14.95	27.95	34.95	60	19
RK40BT3M	40	M16~2.00	90	22.90	9.95	16.99	14.95	27.95	34.95	60	19
RK50BT1M	50	M24~3.00	45	37.90	16.95	24.99	22.95	34.95	44.95	85	30
RK50BT2M	50	M24~3.00	60	37.90	16.95	24.99	22.95	34.95	44.95	85	30
RK50BT3M	50	M24~3.00	90	37.90	16.95	24.99	22.95	34.95	44.95	85	30

Pull Studs RK BT-MAS-403-INCH

Catalogue No.	Taper Size	GX	CHTA in Deg.	D5	DN	DPW	HDD	LF	LPR	L	WF
RK31114	40	5/8"~11	45	0.938"	0.392"	0.636"	0.589"	0.988"	1.264"	2.250"	0.750"
RK31114B	40	5/8"~11	90	0.938"	0.392"	0.636"	0.589"	0.988"	1.264"	2.250"	0.750"
RK31118	50	1.00"~8	45	1.438"	0.668"	1.026"	0.903"	1.384"	1.778"	3.355"	1.250"
RK31118B	50	1.00"~8	90	1.438"	0.668"	1.026"	0.903"	1.384"	1.778"	3.355"	1.250"

Pull Studs ANSI-Style with out Pilot - INCH

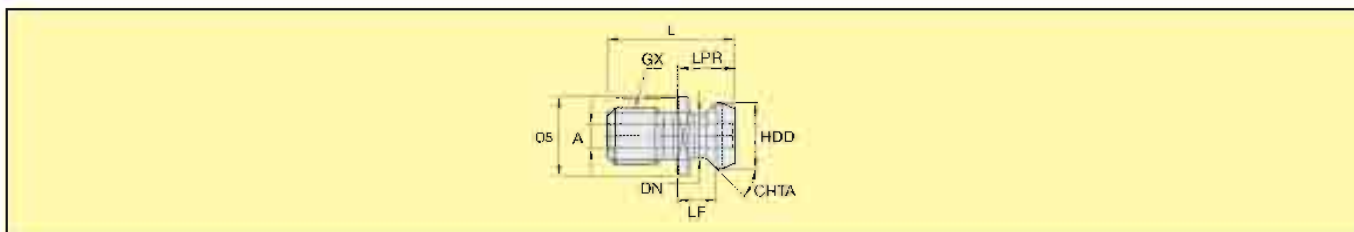

- Pull Stud-ANSI Style without pilot
Inch Thread, Through Coolant
- Order Example – RK40CV

Catalogue No.	Taper Size	GX	CHTA	D5 in Deg.	DN	HDD	LF	LPR	L	WF	A
RK40CV	40	5/8"~11	45	0.900"	0.490"	0.740"	0.440"	0.640"	1.500"	0.750"	0.281"
RK50CV	50	1.00"~8	45	1.400"	0.820"	1.140"	0.700"	1.000"	2.300"	1.250"	0.500"

Technical data BT



BT Shank MAS 403, JIS B6339

Tooling Standard Dimensions – JIS B6339

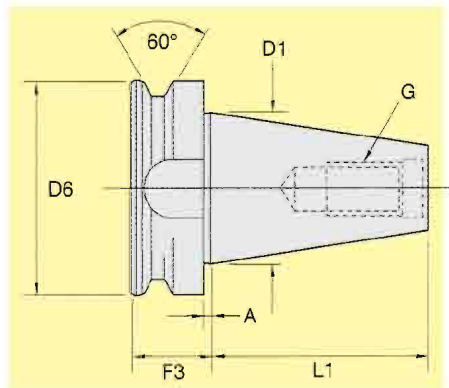

	D1	D6	L1	F3	A	G
30	1.250 (31,75)	1.811 (46,00)	1.906 (48,40)	.866 (22,00)	.079 (2,00)	M12 thread
40	1.750 (44,45)	2.480 (63,00)	2.575 (65,40)	1.063 (27,00)	.079 (2,00)	M16 thread
50	2.750 (69,85)	3.937 (100,00)	4.008 (101,80)	1.496 (38,00)	.118 (3,00)	M24 thread

**Manufactured to MAS-403-1972 standards.*

Form B – Flange Coolant Entry Ports

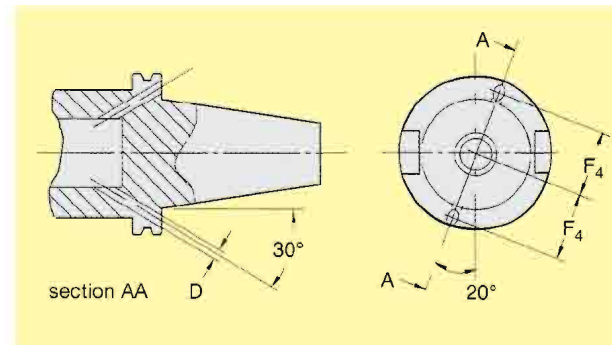

	D	F4 ±.004
30	.157 (4,00)	.827 (21,00)
40	.157 (4,00)	1.063 (27,00)
50	.236 (6,00)	1.654 (42,00)

Form B coolant

Some toolholders are equipped with the form B coolant-style feature.

CAUTION!

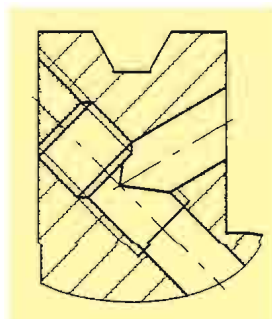

Toolholders are factory set to the form B coolant supply position. When relocating coolant position screws, use of a removable liquid (small screw thread locker) is recommended.

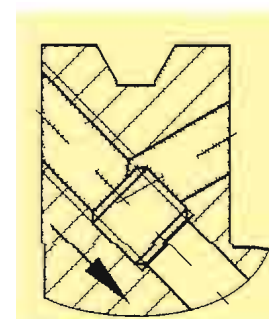

Possible variation of coolant supply to DIN 69871 form AD; tightening screws will stop coolant from escaping through the flange.

Technical data CV



CV- Shank ANSI-B5.50- FORM A/AD & FORM B/AD

Caterpillar (inch) CV – ANSI B5.50

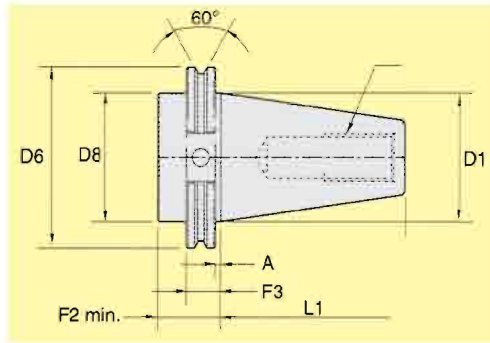

	D1	D6	D8	L1	F2	F3	A	G
30	1.250 (31,75)	1.812 (46,02)	1.250 (31,75)	1.875 (47,63)	1.375 (35,00)	.750 (19,05)	.125 (3,18)	1/2-13 thread
40	1.750 (44,45)	2.500 (63,06)	1.750 (44,45)	2.887 (68,25)	1.375 (35,00)	.750 (19,05)	.125 (3,18)	5/8-11 thread
50	2.750 (69,85)	3.875 (98,41)	2.750 (69,85)	4.000 (101,60)	1.375 (35,00)	.750 (19,05)	.125 (3,18)	1-8 thread

Form B – Flange Coolant Entry Ports

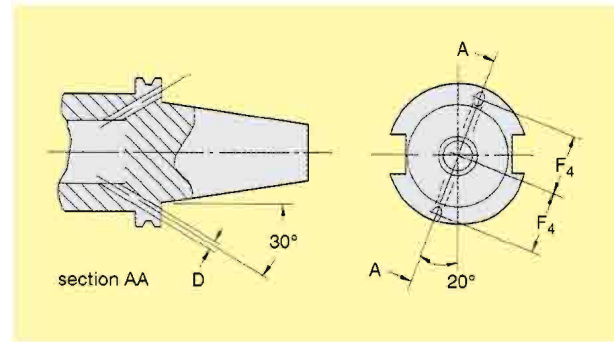

	D	F4 ±0.004
30	.157 (4,00)	.827 (21,00)
40	.157 (4,00)	1.063 (27,00)
50	.236 (6,00)	1.654 (42,00)

Form B coolant

Some toolholders are equipped with the form B coolant-style feature.

CAUTION!

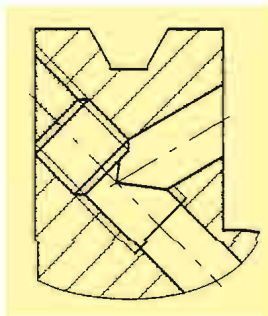

Toolholders are factory set to the form B coolant supply position. When relocating coolant position screws, use of a removable liquid (small screw thread locker) is recommended.

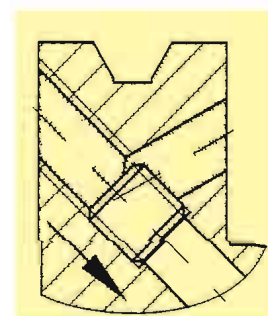

Possible variation of coolant supply to DIN 69871 form AD; tightening screws will stop coolant from escaping through the flange.

Technical data HSK

HSK Shank

- Generally used in machining centers and milling machines with automatic tool changers
- Short taper and face contact
- Taper 1:10
- Central through-coolant available via coolant supply unit
- Micro chip hole to DIN 69893
- Orientation notch in flange
- Depending on the application, Kennametal's HSK balance-by-design toolholders perform effectively up to 15,000 rpm. Kennametal recommends that toolholder assemblies (toolholder, components, coolant tubes, collets, and cutting tools) should be balanced when used at speeds in excess of 15,000 rpm.
- Torque transmission through uneven depth drive keyways at bottom of taper
- Two side-access holes in taper for manual clamping activation
- Indexing slots in V-flange for tool magazine
- High axial and radial repeatability
- Suited to higher speeds compared to the conventional 7:24 steep taper
- Manufactured from premium materials

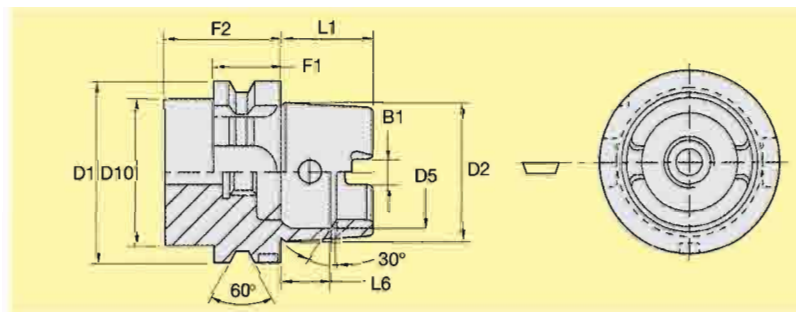

	D1 mm (h10)	D2 mm (ref.)	D5 mm (h11)	D10 mm (max.)	L1 mm (-0,2)	L6 mm (js10)	B1 mm (±0,04)	F1 mm (-0,1)	F2 mm (min.)
50A	50	38	32	42	25	14,13	10,53	26	42
63A	63	48	40	53	32	18,13	12,54	26	42
100A	100	75	63	85	50	28,56	20,02	29	45

ALSO AVAILABLE IN FORM B/ FORM C/ FORM D/ FORM E & FORM F SHANKS ON REQUEST

General Application Instructions

Shank Dimension to DIN 6535 / Form HA and HE

Straight shank to DIN 6535 Form HA - Straight Shank

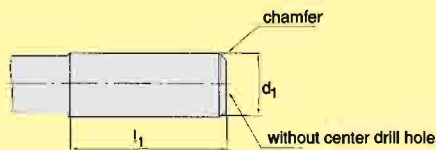

Form HB - with one Clamping Flat (Weldon) d₁ = from 6 to 20 mm

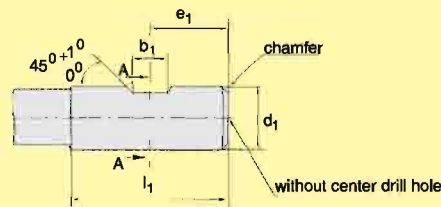

with two Clamping Flat (Weldon) d₁ = 25 to 32 mm

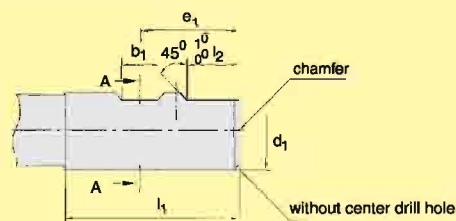

Clamping Chuck for straight shank Form B and Form HB with Clamping Flat d₁ = from 6 to 20 mm

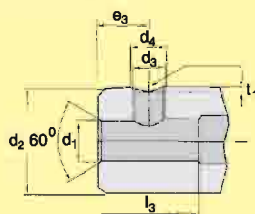

d₁ = 25 and 32 mm

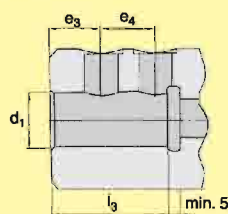

Shank Dimension to DIN 6535 / Form HA and HB

d _{1H6}	with Clamping Notch		h _{1H11}	l ₁	l ₂	e ₁
	l ₁	b ₁				
6	36	4,2	5,1	36	-	18,0
8	36	5,5	6,9	36	-	18,0
10	40	7,0	8,5	40	-	20,0
12	45	8,0	10,4	45	-	22,5
14	45	8,0	12,7	45	-	22,5
16	48	10,0	14,2	48	-	24,0
18	48	10,0	16,2	48	-	24,0
20	50	11,0	18,2	50	-	25,0
25	56	12,0	23,0	56	17	32,0
32	60	14,0	30,0	60	19	35,0

Chuck Dimension to DIN 1835/1, Form E

d _{1H5}	d ₂	d ₃	d ₄	e ₃	e ₄	l ₁	l ₃
6	25	M 6	8	18,0		1,0	35
8	28	M 8	10	18,0		1,3	35
10	35	M10	12	20,0		1,5	39
12	42	M12	14	22,5		1,8	44
14	44	M12	14	22,5		1,6	44
16	48	M14	18	24,0		1,7	47
18	50	M14	16	24,0		1,7	47
20	52	M16	18	25,0	-	2,1	49
25	65	M18x2	20	24,0	25	2,1	54
32	72	M20x2	22	24,0	28	2,2	58

Recommended Clamping Torque for tools with solid carbide shank

Clamping Screw	Clamping Screw
M 6	5 Nm
M 8	10Nm
M 10	16 Nm
M 12	28 Nm
M 14	42 Nm
M 16	50 Nm
M 18	60 Nm

General Application Instructions

Shank Dimension to DIN 6535 / Form HA and HE

Straight shank to DIN 6535

Form HA - Straight Shank

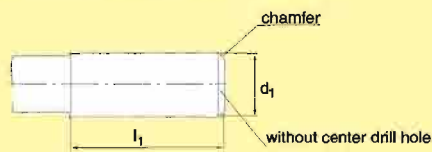

Form HE - with Clamping Notch (whistle Notch)

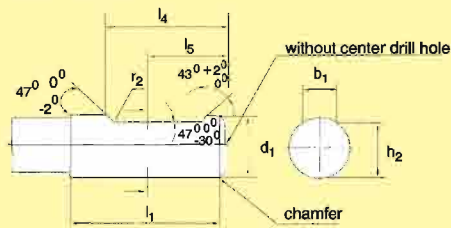

Shank Dimension to DIN 6535 / Form HA and HE

d ₁ H ₆	with Clamping Notch					
	l ₁	b ₁	h ₁ h _{1,1}	l ₄	l ₅	r _{2min}
6	36	4,3	5,1	25	18	1,2
8	36	5,5	6,9	25	18	
10	40	7,1	8,5	28	20	
12	45	8,2	10,4	33	22,5	
14	45	8,1	12,7	33	22,5	
16	48	10,1	14,2	36	24	1,6
18	48	10,8	16,2	36	24	
20	50	11,5	18,2	38	25	
25	56	13,6	23,0	44	32	
32	60	15,5	30,0	46	35	

Note:
For Ø 25 and Ø 32 the notch extends to the shank end!

Clamping Chuck for straight shank Form HE and Form E with Clamping Notch

d₁ = 6 to 20 mm

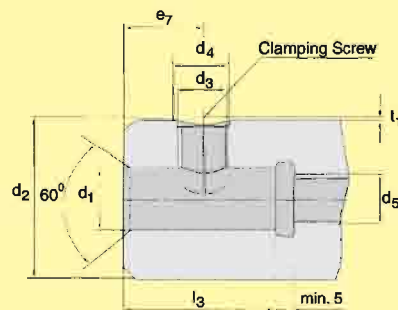

d₁ = 25 and 32mm

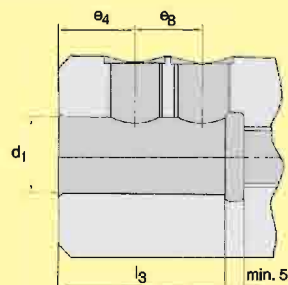

Chuck Dimension to DIN 1835/1, Form E

d ₁ H ₅	d ₃	d ₄	d ₅	e ₇	e ₈	l ₃	t ₁
6	M6	8	M5	18		35	1,0
8	M8	10	M6	18		35	1,3
10	M10	12	M8	20		39	1,5
12	M12	14	M10	22,5		44	1,6
14	M12	14	M10	22,5		44	1,6
16	M14	16	M12	24		47	1,7
18	M14	16	M12	24		47	1,7
20	M16	18	M16	25		49	2,1
25	M18x2	20	M 20	24	22	54	2,1
32	M20x2	22	M 20	24	24	58	2,2

Recommended Clamping Torque for tools with solid carbide shank

Clamping Screw	Clamping Torque
M6	5 Nm
M8	10Nm
M10	16Nm
M12	28 Nm
M14	42 Nm
M16	50 Nm
M18	60 Nm
M20	60 Nm

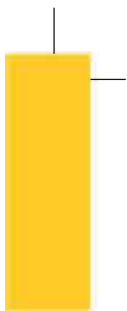

BPTL Hydraulic Chucks for 'Precision Machining'

- TIR within 3 microns at nose & 5 microns at 4 times the cutting tool diameters.
- Improved vibration damping by using patented silicon compound as the pressuring medium.
- Upto 800Nm transmittable torque, depending on the diameter.
- Improved surface finish of the work piece.
- Higher work piece accuracy.
- Up to 50% longer tool life.
- Increased productivity.
- Patented, leak-proof clamping system.
- Repeatability of 3 microns TIR over 50,000 cycles.
- Available on all popular taper shanks, including HSK.

Slim line high-precision chuck

BPTL Hydraulic Quality Chucks for 'High-speed Machining'

- Slim line design and shorter reference dimensions; HSK tapers are also to standardized dimensions.
- Defined piston stroke-against stop-guarantees specified clamping forces.
- Two symmetrical pistons bore for the best repeatability and TIR. One screw for actuation.
- Cutting performance is far less susceptible to heat than with oil-filled high-precision chucks.
- Up to and including 20mm diameter, tools with Weldon or whistle-notch shank can be clamped without an intermediate sleeve, ensuring precision and run out accuracy.
- Excellent vibration damping due to silicon pressurizing medium, tool chatter and vibration are reduced, tool life and accuracy are increased.
- The integral clamping sleeve is hardened and tempered to reduce chuck wear and give a longer service life.
- Extremely high clamping forces, 250Nm at 20mm diameter.
- Up to a speed of 15,000 rpm, BPTL high precision chucks can be used without dynamic balancing. At speed above 15,000 and up to 25,000 rpm, additional dynamic balancing may be necessary.
- All BPTL hydraulic high-precision chucks are individually tested for accuracy and torque transmission. Each chuck receives its own certificate showing transmittable torque etc. to acceptable the following minimum values must be achieved:(The values shown apply to slinline and Standard Chucks.)

Clamping dia. (mm)	Min.transferable torque moment (Nm)
6	12
8	20
10	40
12	70
14	100
16	150
18	210
20	250
25	420
32	800

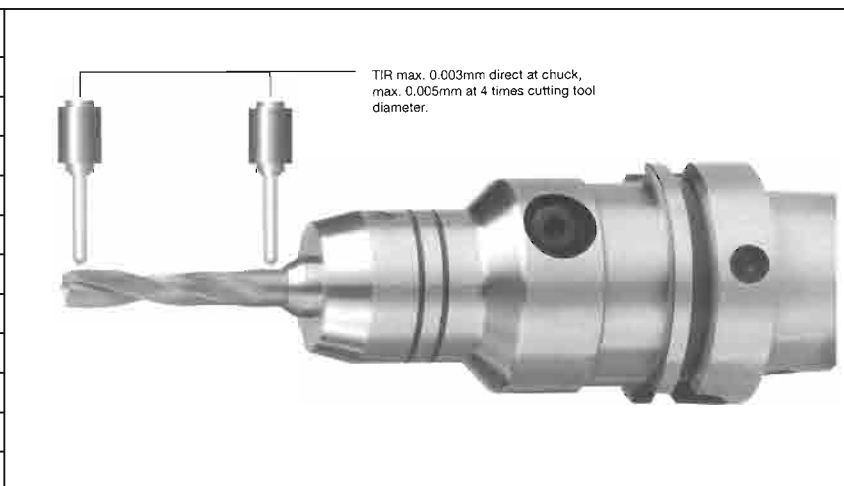

Hydraulic Chuck

Instructions for Use – Hydraulic Tool holders.

Thoroughly CLEAN the tool SHANK and the tool holder BORE. Oil reduces the “Clamping force” by 1/3.

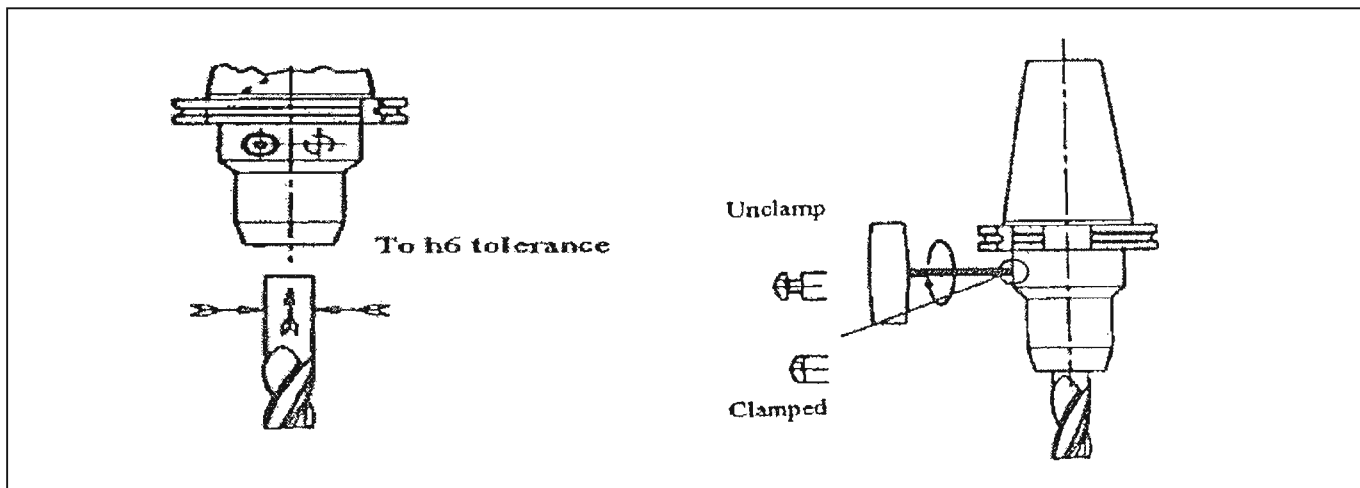

1. Insert the tool to the bottom of the tool holder. Please note tool shank must hold to the “h6” tolerance.
2. Tighten the pressure screw until fully engaged.
3. All tool holders are inspected 100% then individually certified stating actual run out, thus guaranteeing that run out will be no greater than 3 microns at the nose and 5 microns at 4 times diameter. Tool holders can be selected for improved run out specifications to the above. All tool holders are individually torque tested prior to leaving the factory to the minimum values stated below. The listed values are for round shafts all diameters. Weldon and whistle notch shanks up to 20mm dia, all with “h6” shank tolerances held directly in the tool holder.
4. The actuating screw must not be tightened without tool inserted in the chuck.

Shrink Fit Technical details

Shrink Fit Tool Holder Technical Information.

In shrink fit tool holder the internal bore size is slightly manufactured smaller than the cutting tool shank. By application of heat through the heating unit at holding nose area will cause the inside bore to expand & the cutting tool shank can be inserted at this stage. The holding nose is then cooled which shrinks the bore & firmly grips uniformly the shank of the tool holder.

Shrink Fit Tool Holder Advantages

- Greater Clamping Force over Collet Chucks / Hydraulic Chucks.
- Greatly recommended for high-speed application, due to symmetricity as no additional parts are fitted. Improves surface finish & tool life.
- Guaranteed concentricity of 3 microns at nose due to uniform clamping force.
- Narrow nose design is suited for deep cavity.
- Supplied as pre balanced at G 6.3 @ 15,000 RPM
- Recommended to use "h6" tolerance cutting tool shank without flat.

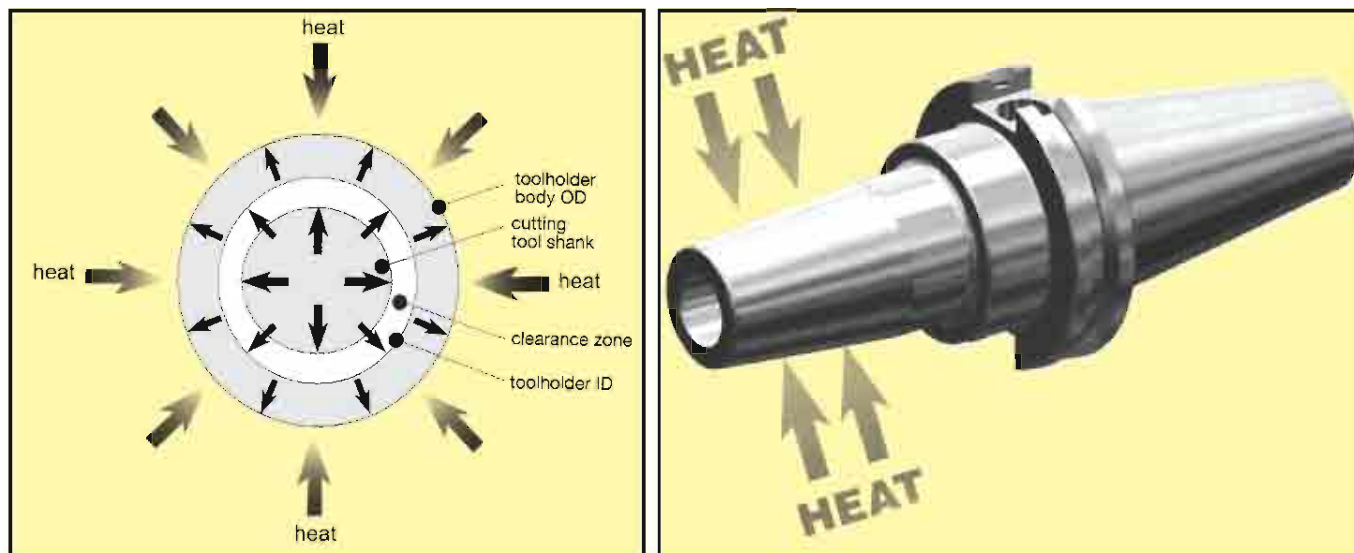

Machining Center Single Angle Assembled Collet Chuck Accuracy & Collet Accuracy Chart as per



DIN 6499 Class II

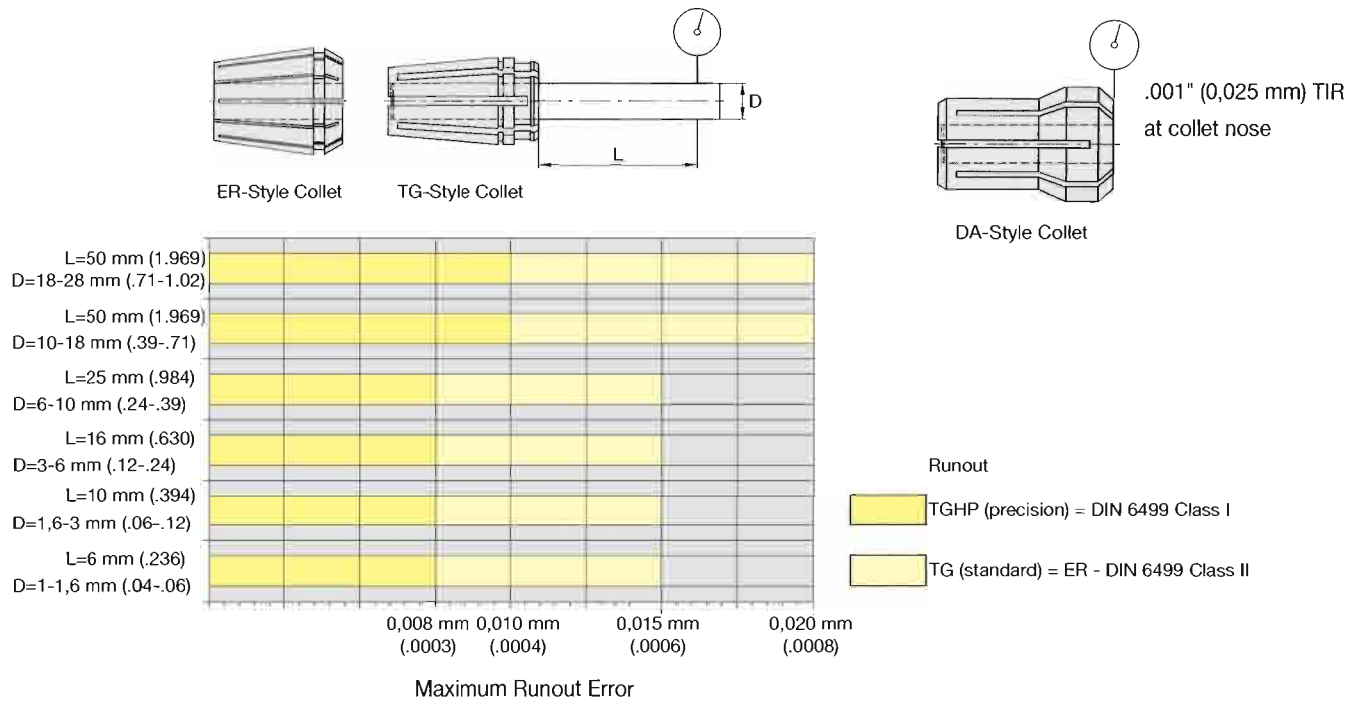

Machining Center Single Angle Assembled Collet Chuck Accuracy

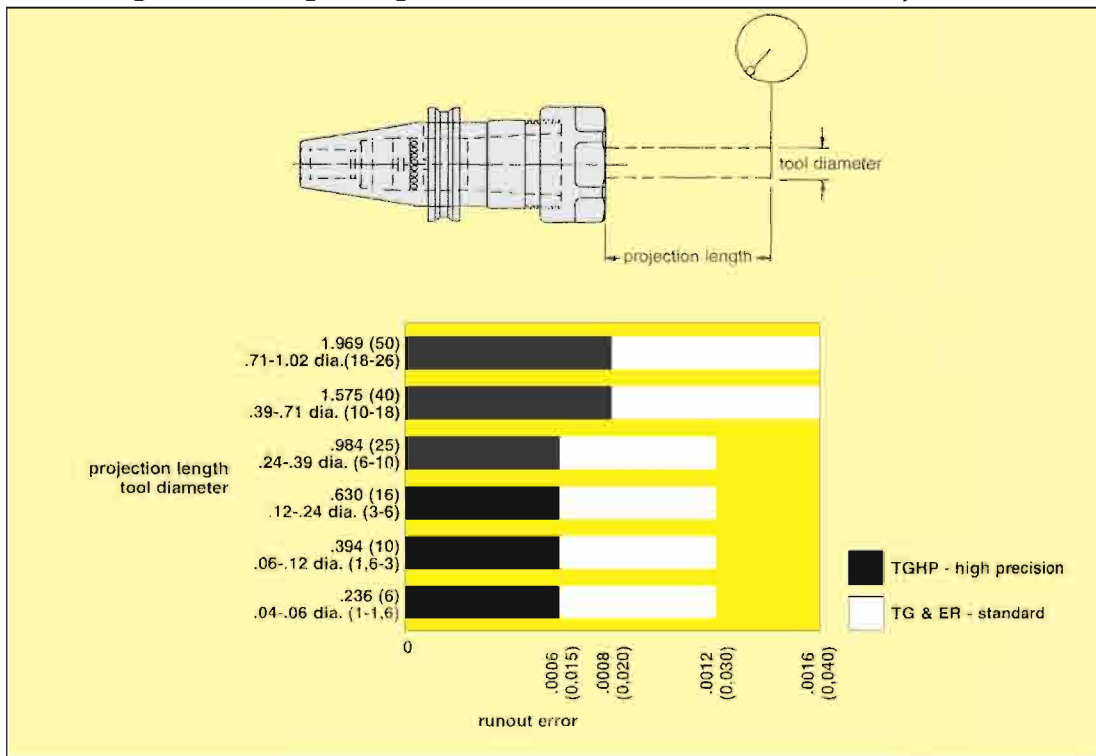



Birla Precision Technologies Limited

B-15/4, MIDC, Waluj, Aurangabad 431 133, India.
Tel.: + 91 240 2554 301, 2554 408, 2554 945, 2554 947- 8.
Fax: + 91 240 2554 302. E-mail: info@birlaprecision.com
www.birlaprecision.com www.birlaprecision.in



Distributed by:

Global Tooling Solutions
PO Box 701, Walpole, MA 02081.
P - 800/985-5390. F - 781/881-0469.
kganshirt@gts-tools.com www.gts-tools.com